

# COW HOLLOW

## NEIGHBORHOOD DESIGN GUIDELINES



APRIL 2001

COW HOLLOW ASSOCIATION



## ACKNOWLEDGMENTS

These guidelines were written by consultants to the Cow Hollow Association and reviewed by the San Francisco Department of City Planning. The CHA wishes to acknowledge the contributions of consultants Lucian R. Blazej, Ian S. Moore and Clark Wilson. Mr. Blazej provided project oversight and Mr. Moore provided project management, research and prepared the Cow Hollow Neighborhood Design Guidelines document. Mr. Wilson prepared the line sketches illustrating typical Cow Hollow neighborhood structures. Mr. Pedro Arce reviewed the report for the San Francisco Planning Department.

## PREFATORY NOTE

The Cow Hollow Neighborhood Design Guidelines contain sections quoted directly from the Residential Design Guidelines of San Francisco (1989). Extensive additional text and graphic materials have been added where required to meet the needs of the Cow Hollow Neighborhood.



# TABLE OF CONTENTS

<b>Section 1. Cow Hollow Neighborhood Design Guidelines Background</b> .....	1
Introduction .....	1
Legal Basis .....	1
Purpose and Intent .....	1
Glossary .....	4
Where the Guidelines Apply .....	5
<b>Section 2. Neighborhood Character</b> .....	7
Topography and Terrain .....	7
Topographic Features of Cow Hollow .....	7
Origins of Cow Hollow .....	9
Defining Neighborhood Character .....	11
Neighborhood Character of Cow Hollow .....	16
<b>Section 3. Residential Design Guidelines</b> .....	19
The Design Process .....	19
Elements of Design .....	20
Siting .....	21
A. Location .....	21
B. Topography and Views .....	23
C. Setbacks .....	25
D. Rear Yards .....	28
E. Side Spacing (Side Yards) .....	30
Building Envelope .....	32
A. Roofline .....	32
B. Volume and Mass .....	34
Scale (Height, Width and & Depth) .....	37
A. Dimensions .....	37
B. Proportions .....	39
Texture and Detailing .....	40
A. Exterior Materials .....	40
B. Ornamentation .....	42
Openings .....	44
A. Entryways .....	44
B. Windows .....	45
C. Garage Doors .....	46
Landscaping .....	48
A. Tree Pruning for the Retention of Mid-Block Open Space .....	48
B. Tree Selection and Placement .....	48



<b>Section 4. Notification and Neighborhood Involvement</b> .....	49
Notification and Story Poles .....	49
Cow Hollow Association .....	49
Neighborhood Involvement .....	49
<b>Appendix</b> .....	51
A. Zoning Districts of Cow Hollow Neighborhood .....	53
B. Analysis of Rear Yard Coverage .....	54
C. Analysis of Building Height .....	55
D. Cow Hollow Association Policies .....	58
D. 1. Rear Yard Setbacks and Open Space .....	58
D. 2. Rear Yard Extensions .....	60
D. 3. Neighborhood Height Policies .....	61
D. 4. Tree Pruning Techniques for View Preservation .....	64
E. Shadow Study .....	66
F. Height Ordinances .....	67



## SECTION 1

# COW HOLLOW NEIGHBORHOOD DESIGN GUIDELINES BACKGROUND

### INTRODUCTION

A long standing city-wide goal has been the preservation and enhancement of the quality of San Francisco neighborhoods. The premium on residential property in San Francisco has encouraged development that has often been unsympathetic to the character of the existing built environment. While the Planning Code provides general limits on the development of lots, the application of these limits may conflict with neighborhood character. The renovation of a residence is a major commitment of time, effort, and money. The reasons for renovation vary: some people renovate as an investment, some to improve their building's design, and some to provide space for a growing family. Whatever the reason, renovations and expansions should respect and improve on the character of the neighborhood and the predominant features of the blockface, and mid-block as well as open space.

### Legal Basis

The Planning Commission adopted the Residential Conservation Amendments to the Planning Code on January 11, 1996, which, among other things, recognized the potential of having Residential Design Guidelines for specific areas of the City (Section 311 of the Planning Code). The Planning Commission, by resolution, can approve the Cow Hollow Neighborhood Design Guidelines (CHNDG). Upon such action, Planning Department staff would implement these guidelines as part of building permit review.

### Purpose and Intent

To a large degree, the character of San Francisco is defined by the visual quality of its neighborhoods. A single building out of context with its surroundings can have a remarkably disruptive effect on the visual character of a place. It affects nearby buildings, the streetscape, and, if repeated often enough, the image of the city as a whole.

Concern for the visual quality of the neighborhoods gave rise, in part, to the November 1986 voter initiative known as Proposition M which established as a priority policy that existing neighborhood character be conserved and protected. To ensure this, the Neighborhood Conservation Interim Controls were adopted in September 1988, which require the City Planning Department to use residential design guidelines in its review of building permit applications. The Planning Commission in 1989 adopted Citywide Residential Design Guidelines to assist in determining whether a new building, or the expansion of an existing one, is visually compatible with the character of its neighborhood. **The purpose of these Cow Hollow Neighborhood Design Guidelines is to assist in determining whether the renovation or expansion of an existing building, or the construction of a new building, is visually and physically compatible with the neighborhood character of Cow Hollow as defined herein.**

The Planning and Building Codes establish basic limitations on the size of a building. A building built out to the legal limits established for height and setbacks and rear yards may, however, result in a building which is not compatible with the character of its neighborhood.

To address this problem, Section 311 of the Planning Code establishes procedures for review of building permit applications in Residential Districts in order to determine compatibility of the proposal with the neighborhood.

**The Cow Hollow Neighborhood Design Guidelines establish minimum criteria for neighborhood compatibility, not the maximum expectations for good design.** Meeting the criteria will not alone assure a successful project. A successful project will require sensitive design, careful execution, and use of quality materials. A thoughtful application of the guidelines will, however, assist in creating a project that is compatible with neighborhood character, and will reduce the potential for conflict and the delay and expense of project revisions.

The Cow Hollow Neighborhood Design Guidelines do not prescribe specific architectural styles or images, nor do they encourage direct imitation of the past or radical departures from the existing design context. There are many appropriate design responses to a given situation. These Guidelines are most concerned with whether the design respects the project's context, and consciously responds to patterns and rhythms on the exterior and interior block-face with a design that is compatible and that will contribute to the quality of the neighborhood.

Because of the diversity of architecture in Cow Hollow, there is great opportunity for design to unify and contribute positively to the existing visual context. **The key issues for the Cow Hollow neighborhood are preservation and enhancement of the neighborhood character as perceived from the block face as well as the rear facades of buildings, which includes enjoyment of the mid-block open space. These play an important role in the definition of a backdrop for lower neighboring districts and for the Presidio, a National Park.** Even after meeting the basic structural criteria set forth in these Neighborhood Design Guidelines, project sponsors and designers must work to sensitively respond to the other visual design characteristics addressed here. Attention to scale, proportion, texture and detailing, building openings, etc. will help to unify the neighborhood in a positive way.

The Cow Hollow Neighborhood Design Guidelines are intended to be used by project sponsors and their designers in the project design process, by neighbors and community groups in their review of projects, and by the Department of City Planning staff and the City Planning Commission in their review and approval or disapproval of projects.

## ORGANIZATION OF THE GUIDELINES AND FUNCTION OF THE ILLUSTRATIONS

The Cow Hollow Residential Design Guidelines are organized as follows:

**Section 2** describes the topography and origins of Cow Hollow and discusses the meaning of the term neighborhood character, describing typical situations the designer may face and specifically defining the neighborhood character, topographic features, and housing styles of Cow Hollow

**Section 3** identifies basic elements of design, analyzes each of them, and presents guidelines for designing new buildings or alterations to assure compatibility with neighborhood character.

**Section 4** suggests an approach to identify the concerns of neighbors early in the design process and ways to better describe the intended building envelope. It also provides information about the Cow Hollow Association.

The drawings are intended to illustrate the text and are sometimes schematic. They are not design examples to be copied or imitated. Although the drawings show only one side of the street, or one side of the mid-block open space, depending on where the discussion affects the front or the rear facade of the building, both sides of the street or the mid-block open space are of concern. The illustrations are of in-fill new construction or alteration of existing buildings on lots with widths varying 25 to 30 feet in low-density neighborhoods. However, the text is also applicable and should be followed on wider lots.

## THE APPENDIX

This publication includes an Appendix, separate from the Neighborhood Design Guidelines, that includes specific discussion and analysis of rear yard coverage and building height, Cow Hollow Association policies on rear yard setbacks and open space, rear yard extensions, height, and tree pruning techniques, shadow study (not included yet) and height ordinances from other Bay Area communities for informational purposes.



## ORGANIZATION OF THE GUIDELINES AND FUNCTION OF THE ILLUSTRATIONS

The Cow Hollow Residential Design Guidelines are organized as follows:

**Section 2** describes the topography and origins of Cow Hollow and discusses the meaning of the term neighborhood character, describing typical situations the designer may face and specifically defining the neighborhood character, topographic features, and housing styles of Cow Hollow.

**Section 3** identifies basic elements of design, analyzes each of them, and presents guidelines for designing new buildings or alterations to assure compatibility with neighborhood character.

**Section 4** suggests an approach to identify the concerns of neighbors early in the design process and ways to better describe the intended building envelope. It also provides information about the Cow Hollow Association.

The drawings are intended to illustrate the text and are sometimes schematic. They are not design examples to be copied or imitated. Although the drawings show only one side of the street, or one side of the mid-block open space, depending on where the discussion affects the front or rear facade of the building, both sides of the street and the mid-block open space are of concern. The illustrations are of in-fill new construction or alteration of existing buildings on lots with widths varying from 25 to 30 feet in low-density neighborhoods. However, the text is also applicable and should be followed on wider lots.

The **Appendix** includes specific discussion and analysis of rear yard coverage and building height, Cow Hollow Association policies on rear yard set backs and open space, rear yard extensions, height, and tree pruning techniques, shadow study, and height ordinances from other Bay Area communities.

## Glossary

The following terms are defined for use in the context of the Cow Hollow Design Guidelines.

**Building Envelope:** the allowable volume defined by height, width and depth that a building may occupy, subject to specific limits and policies

**Exterior Blockface:** the row of front facades facing the street for the length of one block

**Interior Blockface:** the row of rear facades facing the mid-block open space for the length of one block

**Midblock Open Space:** the interior block area shared by the rear yards of all properties on a given city block and defined by the rear facades of buildings

**Neighborhood Character:** the collection of architectural mass, scale, proportion, pattern and rhythm, design and environmental characteristics that determine the quality of life and ambience of a geographically-defined neighborhood

**Setback (Front, Rear, Side):** The dimension a building or portions of are set back from respective property lines

**Rear Yard:** the open space between the rear wall of a subject property and the rear lot line

### Where the Guidelines Apply

The Cow Hollow Neighborhood Design Guidelines apply within the boundaries of the Cow Hollow Neighborhood. Cow Hollow is the rectangular area of the City and County of San Francisco bounded by Greenwich Street in the north, Pierce Street in the east, Pacific Avenue in the south, and Lyon Street in the west. The neighborhood area includes both sides of the street on each of the bounding streets. The following figure illustrates the neighborhood boundaries.

### COW HOLLOW NEIGHBORHOOD BOUNDARIES

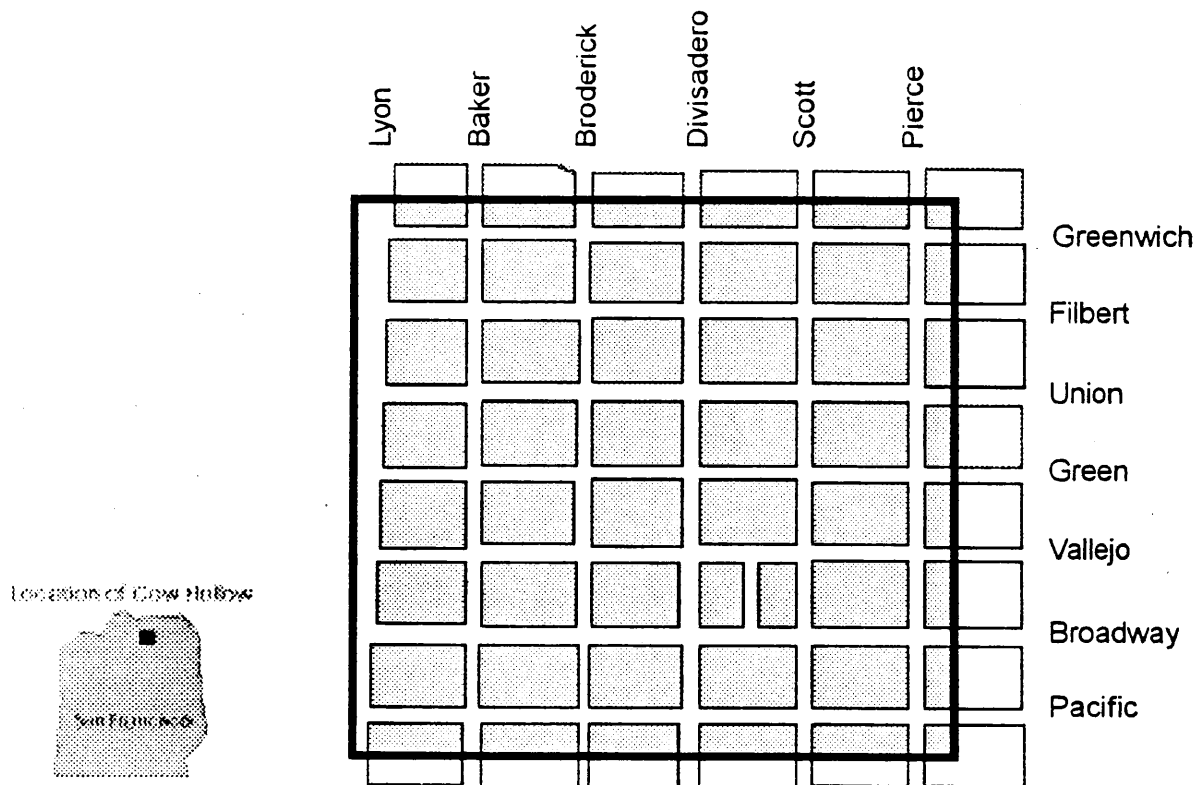



## SECTION 2 NEIGHBORHOOD CHARACTER

### TOPOGRAPHY AND TERRAIN: RELATION TO ARCHITECTURAL DESIGN

The boundary of Cow Hollow has been previously defined in "Where the Guidelines Apply." Cow Hollow homes take advantage of the picturesque setting afforded by its hillside site, located on the north facing slope descending from Pacific Heights to the Marina.

The open, picturesque atmosphere of the Cow Hollow neighborhood is created by the unique hillside setting and views to the north, and by large mid-block open spaces. The Golden Gate Bridge, Presidio, Marina District, Palace of Fine Arts, San Francisco Bay, and Marin County communities are all visible from different parts of the Cow Hollow Neighborhood. Neighborhood architecture affords urban density at a pleasant scale that preserves natural light and views for most residents. The traditional grid street layout provides ease of neighborhood circulation, and block dimensions are characteristic of many older San Francisco residential neighborhoods. The fact that this street and block arrangement is preserved even on the steeper blocks in the neighborhood creates a reasonable uniformity of building lot coverage, building height, views, mid-block open space, and lot setbacks. These are the attributes of individual lots and structures that largely define the Cow Hollow neighborhood character.

Cow Hollow includes a diversity of building types: larger single family detached residences in the higher elevation areas of the neighborhood; one and two family attached residences on smaller lots throughout much of the neighborhood; and, multi-family structures located on corner lots and in the lower elevation areas of the neighborhood. Despite this diversity of building types, the neighborhood is predominately two and three stories.

#### Topographic Features of Cow Hollow

The level east-west ridge along Pacific Avenue serves as the southern boundary of Cow Hollow and generally slopes downward toward the San Francisco Bay. The western boundary of the neighborhood drops from an elevation of 250 feet at intersection of Pacific and Lyon Streets to an elevation of approximately 50 feet in the vicinity of Greenwich and Lyon Streets. The eastern edge of the neighborhood slopes downward from roughly 210 feet from the intersection of Pacific Avenue and Pierce Streets to roughly 35 feet at Greenwich and Pierce Streets. The neighborhood also has considerable variations in elevation from west to east. The third elevation profile below demonstrates the considerable rise and fall along Vallejo Street from west to east. This is a result of the prominent ridge that runs perpendicular to the Bay shore, defined roughly by Divisadero Street.

These topographic features exert a defining effect on the architectural features of the homes and block faces in Cow Hollow. In addition, the topography influences the micro-climate in Cow Hollow, specifically the solar lighting, fog, and wind (Appendix E.) Design techniques for preserving these architectural characteristics and resultant environmental quality in the neighborhood are included in Section 3 of this document.

**Cow Hollow Neighborhood Topography**

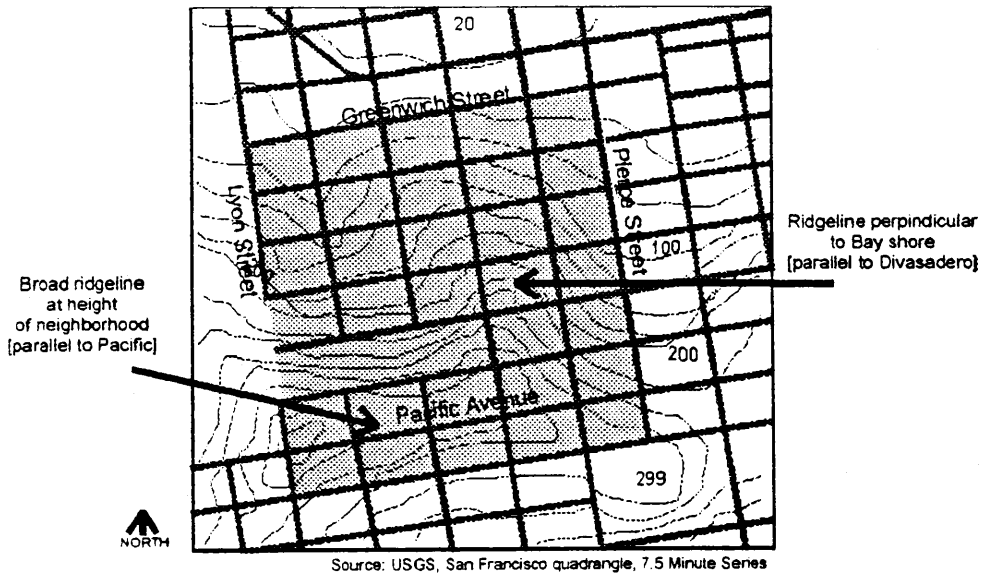

Source: USGS, San Francisco quadrangle, 7.5 Minute Series

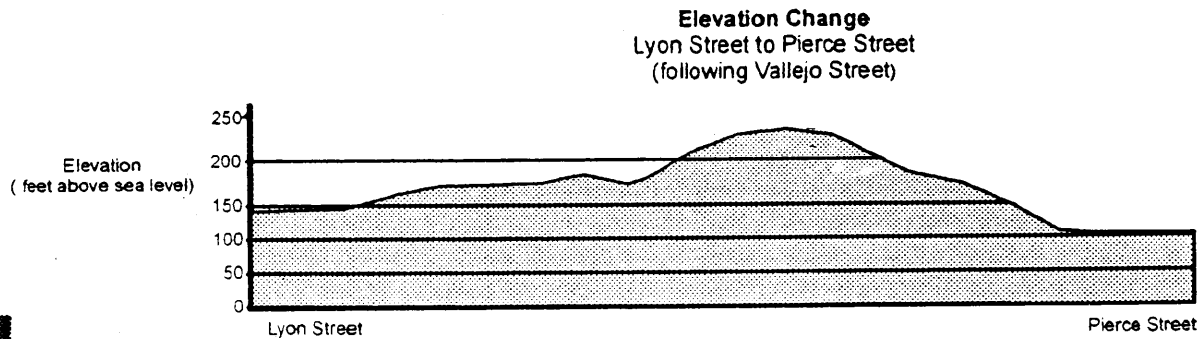
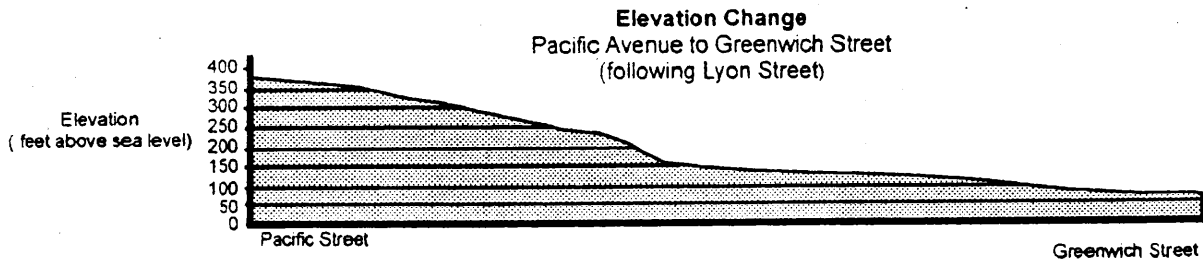
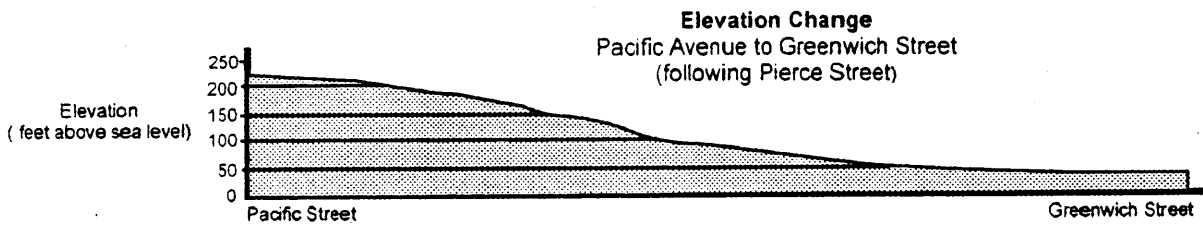

## ORIGINS OF COW HOLLOW

Once home to a brewery and Chinese vegetable gardens, and bordered by a soap factory, tannery, streetcar factory, and laundries, Cow Hollow is today one of the finest residential neighborhoods in San Francisco. (John L. Levinsohn, *Cow Hollow: Early Days of a San Francisco Neighborhood from 1776*). The neighborhood is a unique microcosm of the full range of architectural styles popular for single family residences in San Francisco before 1925.

Stark sand hills originally stood as background to pastures used first for dairy cows and then cattle. Natural springs abounded in Cow Hollow, running down to Washerwoman's Lagoon, somewhat north of our present Filbert Street. Businesses were established there using the water for laundering and for tannery processing. Fertile and well-watered adjacent lands were a source of much produce for consumption in San Francisco beginning in the 1850s. Land north of Lombard between Scott and Steiner, as well as up the hill at Pierce and Green Streets was cultivated for produce by Chinese laborers. By the 1870s there were about 30 dairies in the vicinity, the largest with about 200 cows. Residents complained of unsanitary conditions attributable to the dairies, and the tannery was equally unpopular because it polluted the spring-fed waters of the lagoon. By the 1880s both cows and tannery were gone, and a few significant residences had been constructed in the neighborhood.

The first grand home in Cow Hollow was built in 1865-66 by Henry Casebolt at 2727 Pierce Street across from the Chinese gardens. Henry Casebolt, a Virginia blacksmith, made a fortune during the Gold Rush era and established a factory in 1871 at Union and Laguna to manufacture cars for his Sutter Street Railway. Designated as Landmark Number 51 by San Francisco's Landmarks Preservation Advisory Board, the house today is considered a masterpiece of the Italianate style. Set back in the center of the block, its most prominent feature is the centrally located porch, flanked by double stairways. Salvaged ship timbers were used for much of the structure. The white wood exterior was once speckled with dark tones to mimic stone.

The Casebolt house graced the cover of the popular book Here Today published by the Junior League of San Francisco in 1968. Here Today is credited with influencing the formation of the Landmarks Board, as well as the city's nonprofit Foundation for San Francisco's Architectural Heritage.

Some of the oldest houses in San Francisco still stand today in Cow Hollow because they were subsequently moved here from other neighborhoods, many of which burned in 1906. This is a highly specialized form of historic preservation which relies on either clairvoyance or extremely good luck! (William Kostura, "Itinerant Houses: a History of San Francisco's House Moving Industry", The Argonaut Journal of the San Francisco Historical Society, Spring 1999). A reporter in 1901 warned that Cow Hollow "bids, fair to become a wholly

unique neighborhood of second-hand houses and out of date architecture.” (“Tramp Houses of San Francisco”, San Francisco Chronicle, November 17, 1901. Sunday Supplement, p.2) Today we appreciate our wholly unique neighborhood, which retains particularly fine examples like 2828 Vallejo, on the northeast end of the block between Broderick and Baker. Built In 1880 or 1881 and located at that time at 2120 Broadway, the house may be the oldest Queen-Anne style residence in San Francisco. It was moved in 1895, when the original site was purchased by James L. Flood for his new mansion, which is now the home of Hamlin School. The house at 2828 Vallejo retains a now unusually deep setback and is pictured on page 23 of Here Today.

New home construction in Cow Hollow was concentrated after 1890 and in the first two decades of the century, in a variety of Victorian styles including Stick-Eastlake, Queen Anne and Edwardian. The pace of construction increased significantly after the earthquake and fire of 1906, and in about 1911 in anticipation of the Panama-Pacific International Exposition of 1915. In the 1920s houses were built in Mediterranean, Mission, Romanesque Revival, Tudor, and California Craftsman styles. There was little new construction in the 1930s, however Victorian houses were frequently remodeled from 1900 on in these newer styles. Home-owners also sought to reduce their fire insurance premiums by removing the flammable Victorian decoration and covering their houses with stucco.

By the 1940s some of the large single family homes in the neighborhood had been converted, often illegally, to boarding houses and apartments. Among other factors were the changing economy and the need to house families of soldiers newly stationed in the Presidio. In October of 1946 the Board of Supervisors defeated a resolution which would have rezoned to single family houses (RH-1) ten lots on the west side of Broderick Street between Green and Union Streets. The argument went to the board after a property owner sought a building permit to allow the construction of apartments in a house at 2700 Green Street.

These actions angered resident Elizabeth C. Lawrey, who was told by the Zoning Division of the Planning Department that the whole neighborhood was a lost cause because it was made up of large old houses whose only future lay in their conversion to boarding houses and apartments. Under the auspices of the Planning Department, Ms. Lawrey herself surveyed 45 blocks to show that Cow Hollow was in fact a solid neighborhood of single family homes, and the Planning Commission admitted their error. With four other neighbors Lawrey formed the Cow Hollow Improvement Club, which grew to 360 families. This organization exists today as the Cow Hollow Association which actively participates in planning related activities concerning the neighborhood and acts as a clearinghouse for information from various city departments to members. During Ms. Lawrey's 20 year tenure as Zoning Chairman, illegal uses were cleaned up and 20 to 25 blocks were rezoned from apartments and flats to single family and single family detached homes. The already established apartments and flats were grandfathered in (Marina Union, February 1990.)

Thanks to the early efforts of the Improvement Club, residents today continue to enjoy the first and only park in the neighborhood, Cow Hollow Playground, which is hidden in the center of the block bounded by Filbert, Greenwich, Baker and Broderick streets. With only a handful of grandfathered commercial establishments Cow Hollow remains today an exclusively residential and historic neighborhood.

## **DEFINING NEIGHBORHOOD CHARACTER**

Ultimately, the concern to preserve neighborhood character extends beyond individual neighborhoods to the well-being of the City as a whole. As the San Francisco Residential Design Guidelines point out, "...to a large degree the character of San Francisco is defined by the visual quality of its neighborhoods. A single building out of context with its surroundings can have a remarkably disruptive effect on the visual character of a place. It affects nearby buildings, the streetscape, and if repeated often enough, the image of the City as a whole."

Concern for the visual quality of the neighborhoods gave rise, in part, to the November 1986 voter initiative known as Proposition M, which... established as a priority policy, "that existing neighborhood character be conserved and protected." With respect to specific neighborhoods, the San Francisco Residential Design Guidelines define particular criteria and guidelines that will be described and made specific to Cow Hollow in this and the next section. Neighborhood character is first defined, as follows.

### **What is the Neighborhood?**

In assessing whether the physical characteristics and visual appearance of a building expansion or construction of a new one conserves the existing neighborhood character, neighborhood is considered at two levels:

*The broader context.* Here the concern is how the building relates to the character and scale created by the collection of other buildings in the general vicinity. The buildings on both sides of the street in which the project is located are particularly relevant.

*The immediate context.* Here the concern is how the building relates to its adjacent buildings or, in the case of an enlargement, how the addition relates to the existing structure and how the form of the new or enlarged building impacts the adjacent buildings.

### **What is the Block Face?**

The Block Face is defined as the row of facades for the length of one block. The topography of Cow Hollow shows a significant drop from a ridge running along Pacific Avenue; as a result of this the public perception of buildings is not limited to their front facades, but includes the

rear facades when visible from lower streets or from public areas. In consideration to this, the Block Face consists of two facets: a) the Exterior Block Face, defined by the row of front facades facing the street, and b) the Interior Block Face, defined by the row of rear facades facing the mid-block open space.

### **What is the Mid-Block Open Space?**

The Mid-Block Open Space is the open area in the center of a block, formed by the sum of the rear yards of the properties within the block. The Mid-Block Open Space in the Cow Hollow neighborhood, contributes to the broader cityscape of San Francisco, particularly when seen from the adjacent neighborhoods, the shoreline, the Bay, and the Presidio. Due to the inclined slopes of the upper parts of the neighborhoods, the rear facades of buildings play a very important role because they contribute to the image of the City, while the vegetation in the Mid-Block Open Space, in general, softens the building edges and creates a balance between nature and the built environment. The Mid-Block Open Space adds to the quality of life for the immediate residents .

### **RESPECT OR IMPROVE UPON THE CONTEXT: FLEXIBILITY IN DESIGN**

In certain neighborhoods, the visual character will be so clearly defined that there is relatively little flexibility to deviate from established patterns. However, in the majority of cases there will be greater leeway in design options.

Building patterns and rhythms which help define the visual character should be respected. A street may have a pattern and a rhythm which unify the rows of buildings on either side. A sudden change in this pattern, an over-sized bay window or a blank facade among more detailed ones, for example, can appear disruptive and visually jarring.

In many areas, architectural styles are mixed or significant demolition and redevelopment have already occurred. Other areas show little visual character and seem to be awaiting better definitions. Here, design should go beyond compatibility with the existing context; it should take the opportunity to help define a more desirable future neighborhood character.

The following discussion is intended to help clarify the restrictions and opportunities presented by a particular neighborhood context and to understand the degree of design flexibility that exists.

### **Clearly Defined Visual Character**

On some block faces, existing building patterns and architectural styles will strictly define the options for new development. A predominant visual character is clear in the strong repetition of forms and building types in the following drawing.



A small deviation in this neighborhood pattern would draw a great deal of attention to a new structure—attention that is damaging to the existing street character, as shown below.



**ABOVE FIGURE - SIMULATION FOR ILLUSTRATIVE PURPOSES**

### **Complex Situations**

In other situations, building forms and structures are more varied, yet the row still 'works' and the buildings share a strong, unified sense of character. Patterns in building siting, form, proportion, texture, detail, and image are strong but more subtle than in the previous example. Consider the following example.



This situation is typical of Cow Hollow. While there are many groups of buildings with similar design, it is rare to encounter an entire block face of uniform visual character in the Cow Hollow Neighborhood. The complex situations in Cow Hollow often involve three or more primary building types per block face.



### Undefined Visual Character

In many block faces, an overriding visual character may not be apparent, or the character may be mixed or changing.



When no clear pattern or style is evident on a block face, a designer has both greater flexibility in design and a greater opportunity (as well as responsibility) to help define, unify, and contribute positively to the existing visual context. Existing incompatible or poorly designed buildings in the project's area, however, do not free the project sponsor from the obligation to enhance the area through sensitive development.

The following examples show the great flexibility of design solutions when the neighborhood character is undefined. Each response, however, is derived from existing visual patterns and each attempts to unify the block face.

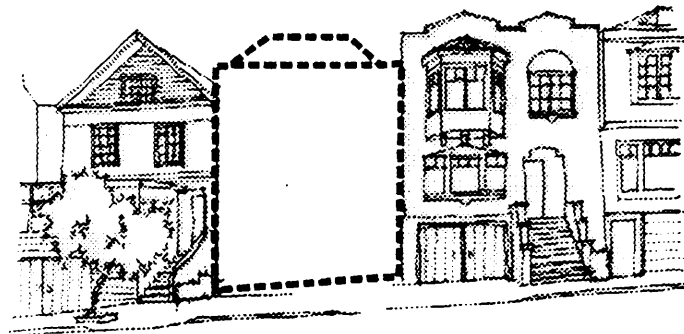
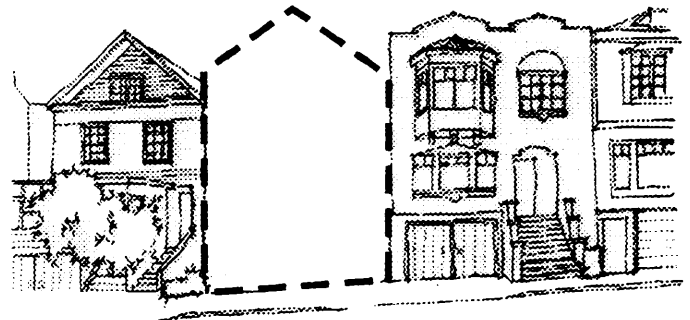
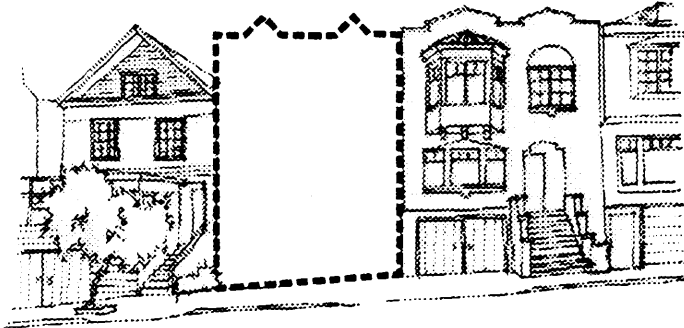

### **New Visual Character**

When the existing visual character offers little interest, new construction or extensive remodeling should seek to improve the context. When a row of new residential buildings or single building on a wide lot is proposed on a block where the existing housing has poor visual character, a unique opportunity to define a more desirable future visual character of the area is presented. The new building or buildings then become the context with which later construc-

tion must be compatible. In these cases, the facades of individual buildings or vertical facade dimensions, in the case of a very wide building, should not be either uniform or entirely different from each other.

## NEIGHBORHOOD CHARACTER OF COW HOLLOW

Cow Hollow has evolved to contain a mix of architectural styles. Often, there will be three or more different styles on one block face, but a unifying rhythm is still maintained. Thus, Cow Hollow can be considered a **complex situation**, as described above, in which building forms and structures are varied, yet the row still 'works.' Sketches illustrating the variety of structures found in Cow Hollow are included.

### Cow Hollow Neighborhood Character: Building Types

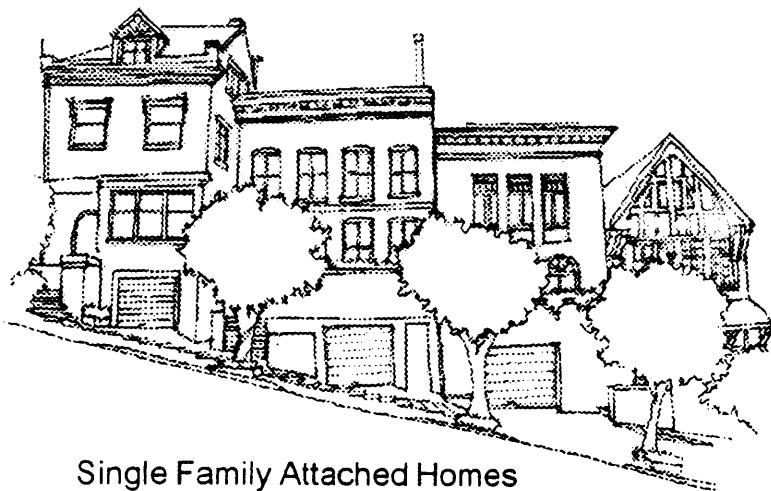

Single Family Attached Homes  
on Hillside Slope



Corner Multi-Family Attached Units  
on Level Slope



Single Family Detached Homes  
on Level Slope

**Neighborhood Character Sub-Areas**

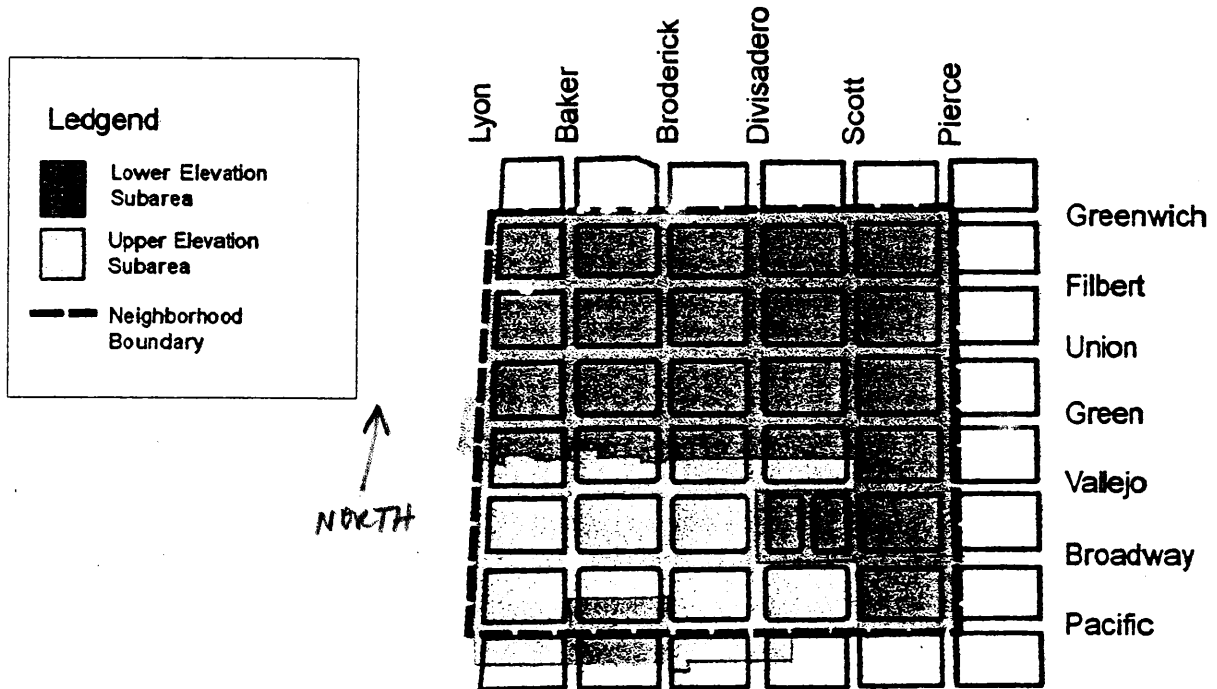

Building types contribute significantly to the neighborhood character of Cow Hollow, and define two sub-areas characterized by similarity of building uses and building dimensions. They are considered under the subsection titles "Scale" in Section 3 of this document. These scale dimensions include **Height, Width** and **Depth**, and are considered in the context of the neighborhood sub-areas. For each of the dimensions, specific neighborhood design guidelines are provided for the two neighborhood subareas in the "Scale" subsection.

The two distinct subareas include the **Upper Elevation Sub-Area** consisting of lots zoned for single family detached homes, and the **Lower Elevation Sub-Area**, consisting of predominately lots zoned for single and two-family dwellings.

The Upper Elevation Sub-Area of Cow Hollow includes the general area bounded by Pacific, Lyon, Vallejo, and Scott. This Upper Elevation Sub-Area is characterized by larger homes on larger lots. There are, however, some blocks within the Upper Elevation Sub-Area that are not zoned for single family detached homes. These exceptions include the block of single family homes bounded by Broadway, Divisadero, Vallejo, and Scott, and the southern half of the Pacific, Baker, Broadway, and Broderick block. These two areas are therefore not included in the Upper Elevation Sub-Area.

The Lower Elevation Sub-Area of the Cow Hollow Neighborhood consists primarily of single and two-family homes. The Lower Elevation Sub-Area includes the general area bounded by Green, Lyon, Greenwich, and Pierce. The need for consistency of scale in this lower elevation sub-area is a primary focus of these Neighborhood Design Guidelines. The fact that single and two-family residences are interspersed throughout the majority of the neighborhood demonstrates the need for a consistent scale and building dimensions across zones.

## SECTION 3 RESIDENTIAL DESIGN GUIDELINES

### THE DESIGN PROCESS

For current Cow Hollow residents and future residents considering building a new home or adding to or otherwise making building modifications or expansions to their homes, it is important to identify those features or elements that give the building its visual character. A two-step approach can be useful in identifying the design elements that contribute to the visual and neighborhood character of a building. This approach involves:

- (1) examining the building from afar to understand its overall setting, architectural context and siting characteristics; then,
- (2) moving up close to appreciate the building's design details, materials and the craftsmanship and surface finishes evident in these materials.

Step one is to identify the overall character of the building, which involves looking at its distinguishing physical aspects without focusing on its details. The main contributors to the building's overall character are its setting, shape, roof and roof features, projections (such as bay windows, eaves, and balconies) recesses, voids, window and doorway openings, and the various exterior materials.

Step two involves looking at the building at arms length to see the surface qualities of materials, such as their decoration, building materials, and texture, or evidence of craftsmanship and age. In some instances, the visual character is the result of the juxtaposition of materials that contrast in their size and texture. A great variety of surface materials, texture, and finishes contribute to a building's character, which is fragile and easily lost when these materials are replaced with inappropriate substitutes.

The following sections give details on the elements of design and the design guidelines that are relevant to maintaining the neighborhood character of Cow Hollow.

## ELEMENTS OF DESIGN

Following are the six basic elements of residential design, most of which have components. For each element, we will give a definition, a series of questions emphasizing the design issues related to the element, and a series of guidelines to follow to ensure that the new design is compatible with existing ones, i.e., with the neighborhood character of Cow Hollow.

### 1. **Siting**

- Location of a project site, and its topography
- Setback of the building from the front property line
- Rear Yard, i.e., the setback of the building from the rear property line
- Side Yard, i.e. spacing between buildings and light wells

### 2. **Building Envelope**

- Roofline: the profile a building makes against the sky, and the organization of projections above the roofline
- Volume and Mass as expressed by the visible facades

### 3. **Scale** (Height, Width & Depth)

- Dimensions of the elements which make up the building's facades
- Proportions of the building, and of the elements of its façade

### 4. **Texture and Detailing**

- Materials and Colors used to finish the surface of the building
- Ornamentation used, including the amount, quality, and placement

### 5. **Openings**

- Entryways -The pedestrian entries into the buildings
- Windows -How they are articulated and used in the façade
- Garage Doors -The vehicular entries into the building

### 6. **Landscaping**

- Tree Pruning for the Retention of Mid-Block Open Space
- Tree Selection and Placement

## 1. SITING

The topography and location of the project lot and the position of the building on that site guide the most basic decisions about design. The Location, Front Setbacks, Rear Yards, and Side Spacing will be particularly important to the adjacent neighbors and for maintaining or creating rhythm along the exterior and the interior block face, and maintaining a sense of common open space in the interior of the block.

### A. Location

Location refers both to the topography of the site (is it on a hill, in a valley, or along a slope?) and to its position in relation to other buildings and significant urban features.

- *Does the site draw attention to itself because of its topography or position on the block?*
- *Will the project be competing for attention with neighboring structures?*

### Respect the Topography of the Site

New buildings should not disregard or significantly alter the existing topography of a site. The context should guide the manner in which new structures fit into the streetscape, particularly along slopes and on hills and in relation to mid-block open space.

The following drawing shows a harmonious streetscape typical of Cow Hollow, in which the buildings respect the topography and the architectural context, stepping down the hill.



From the ridge following Pacific Avenue parallel to the Bay shore, Cow Hollow generally slopes downward toward the San Francisco Bay. The topographic map and profiles in Section 2 of this document show the overall topography of the neighborhood.

The significance of this topography with regard to neighborhood character is that there are few level lots in Cow Hollow. Regardless of where a lot is located in the neighborhood, neighbors may be located above or below the elevation of any subject property. Sensitivity to topography is extremely important in this neighborhood environment.

In the following drawing, the new building (the building in the middle) disregards the topography of the site: it has been built to the same level as the first building from the left, so that its elevation seems forced and the pattern of buildings stepping up the hill is broken.



ABOVE FIGURE – SIMULATION FOR ILLUSTRATIVE PURPOSES

For houses on slopes, terracing allows each successive residence to gain light, air, private and shared open space, and, in many cases, full or partial views. This terracing is important to adjacent neighbors in block faces with significant slope parallel to the street. Terracing in this arrangement preserves lateral access to light and views. Terracing is equally important to up- and down-slope neighbors located on block faces with slopes perpendicular to the street frontage. Terracing in this arrangement preserves light and views from the front and rear of hillside homes. Many of the hillside homes in Cow Hollow use a reverse plan, with large picture windows at the rear, in their living and dining rooms, while the homes behind and downhill from them are carefully designed to be below the line of sight from the homes above. The strength of this design, which takes full advantage of available views, will be undermined if the relation of the structure to the topography is not respected.

## B. Topography and Views

The siting of the homes in Cow Hollow is one of the most important factors defining neighborhood character. As described in the Neighborhood Character of the Cow Hollow discussion in Section 2 of this document, the majority of the buildings are on terraces that follow the slope.

Thus, in Cow Hollow, the most important features that emerge from the integration of architecture and topography is harmony between the terrain and the built environment and views available from many of the homes and from their rear yards. There is ample precedent in Bay Area communities for the preservation of existing views, as described in Appendix F, which should be consulted for details of view preservation ordinances and guidelines in the Hiller Highlands, Berkeley, and Tiburon. Although to some extent the assessment of the impact of an addition to an existing structure on views from the surrounding homes is subjective, the ordinances and guidelines of these Bay Area communities show that it is possible to make these subjective assessments fair to both holders of existing views and to those wishing to build. It is also possible to formulate objective criteria to minimize obstruction of existing views. These communities endorse a combination of such objective measures and professional judgement by planning staff, to evaluate the effects of vertical additions on views.

In the hillside community of Cow Hollow, preservation of the views resulting from the relation of the topography to the existing architecture is a consideration when remodeling is planned or a new home is to be built. In many areas the streets are so steeply terraced (with steep slope between streets) that a vertical addition to a home in the lower street will be well below the line of sight from windows and yards of uphill homes, and therefore, obstruction of views by such addition will not be a major concern. In other areas, terracing is more shallow (in the Lower Elevation Sub-Area of the neighborhood) such that the uphill homes do not presently have views, so a vertical addition would not deprive the uphill home from a view. However, there are areas in which the depth of terracing of the streets is intermediate, so the addition of a story on a downslope home would impact the views from an upslope home.

It is in these moderately terraces areas that the criteria such as those used by the Hiller Highlands, Tiburon, and Berkeley can be applied. Various solutions to minimize view impact in these situations may pertain, as shown below.

These principles can be integrated into both new construction and building expansions in Cow Hollow. For example, as in the following drawing, on a home downslope from another, instead of a vertical addition (right), a rear addition one story lower than the existing structure should be considered (left), provided that it does not encroach within the required open area, to minimize interference with the view from the up-slope home.

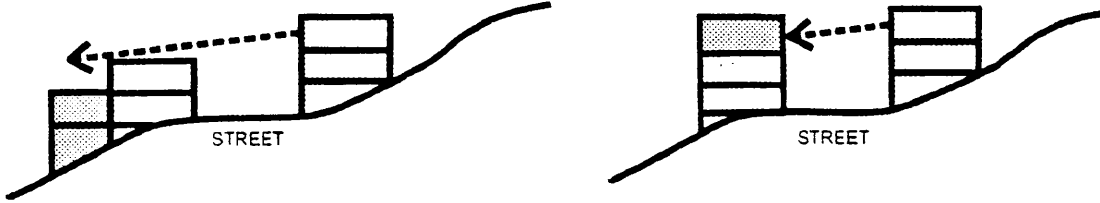

If the severity of the slope and/or the size of the yard precludes the above solution, developing the lower, unfinished story of the home largely within the existing building envelope should be considered, as shown below.

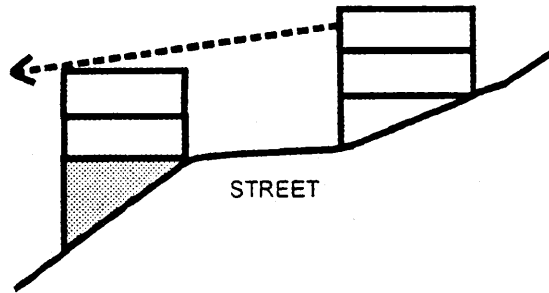

If a down slope home considering a vertical addition is across the street from an up slope home, a front setback or angle-cut on the planned additional story may preserve view for the up slope home and its rear yard, as in the following drawing.

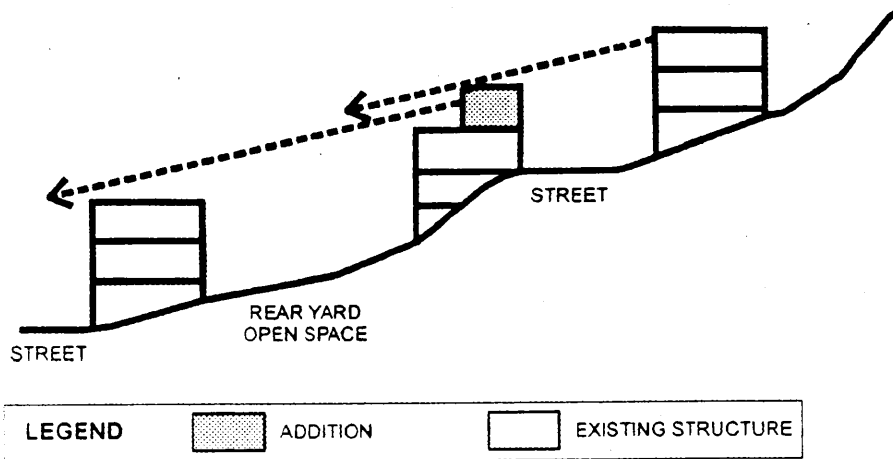

## Emphasize Corner Buildings

Corner buildings play a stronger role in defining the character of the neighborhood than other buildings along the block face. They can act as informal entryways to the street, setting the tone for the streetscape which follows.

Design for corner buildings should recognize this by giving the building greater visual emphasis. Emphasis may be given by greater height, a more complicated form or projecting façade elements, or richer stronger decoration.

Corner buildings, which have two street facing facades, create a unique design challenge, particularly if the internal organization of the building is that of an interior building with two blind sides. Placed on a corner, one of the sides is now an exposed façade which should be fenestrated, articulated, ornamented and finished so it is comparable to the front façade. The following illustration represents a well-designed corner home in Cow Hollow.

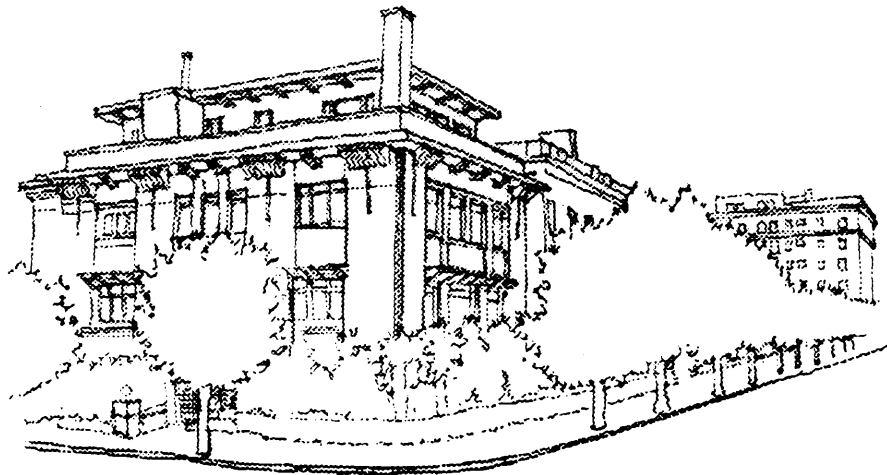

## C. Setbacks

Building setbacks are the distance between the structure's edges and the front property lines. The pattern of setbacks helps establish a rhythm to the block face and provides a transition between the public sidewalk space and the privacy of the building.

- *Is there an existing pattern of building setbacks?*
- *What effect will changing this pattern have?*
- *Do the proposed setbacks create new building corners along the block face?*

## Respect Setback Patterns

A setback that goes against the established pattern will be disruptive to the neighborhood character.

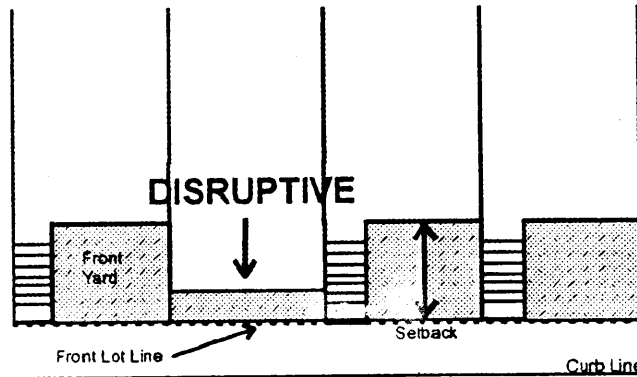
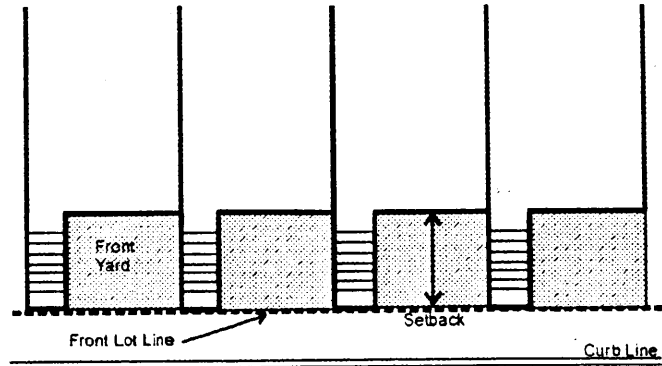

In Cow Hollow, within any particular block face, each building is set back from the property line to a similar degree (Portions of the facades are recessed even further creating partial setbacks). The setbacks help to define the transition between the private spaces and public street areas. Landscaping can help soften this transition. Existing patterns of landscaped front setbacks should be retained.

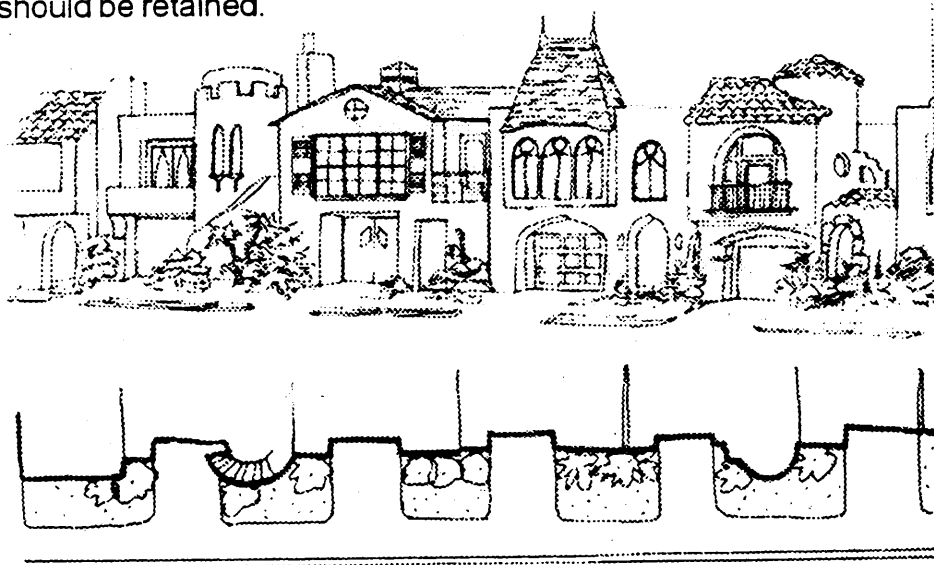

The front gardens in the setbacks of many homes in Cow Hollow are an important asset of the neighborhood. Elimination of these gardens not only damages neighborhood character but also depreciates the value of the home. Drought resistant plants and automatic-drip irrigation systems can facilitate maintenance of front gardens. (See Landscaping.)

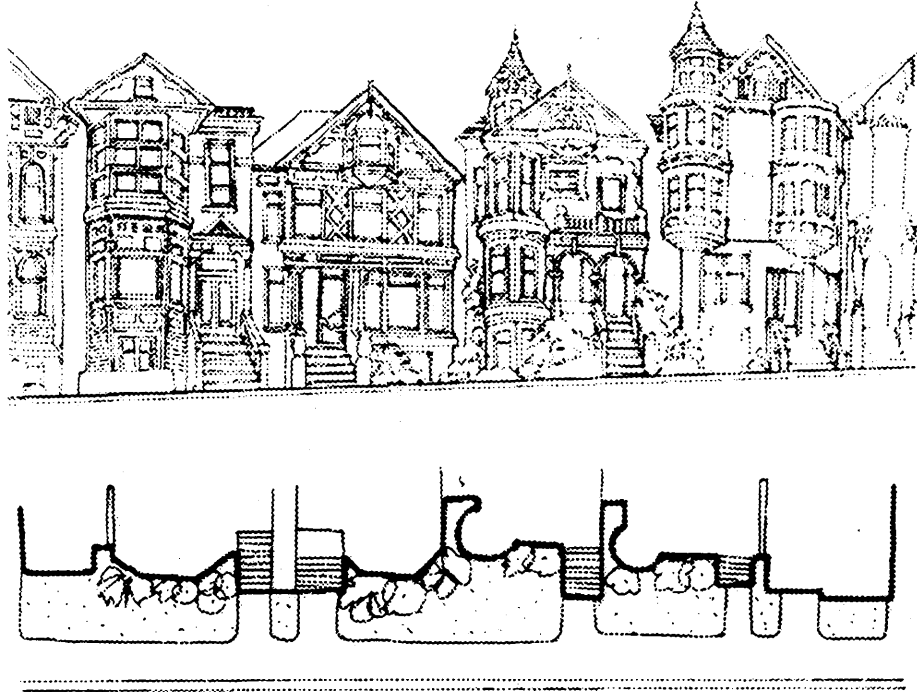

### **Respond to Building Corners Created by Setbacks**

Changes to a uniform setback pattern can create building corners along the block face. These corners often draw attention to themselves and can take on a special role in the composition of the streetscape. They should be designed to acknowledge this role.

## Acknowledge Significant Neighboring Buildings

In some cases, a proposed project is adjacent to a historically or architecturally significant building. These structures are often set back from the street or are on wider lots with gardens in front. For these lots, open space can sometimes be even more important than the building itself. The setback treatment should be sympathetic to the importance of the building, its setback and the open space.

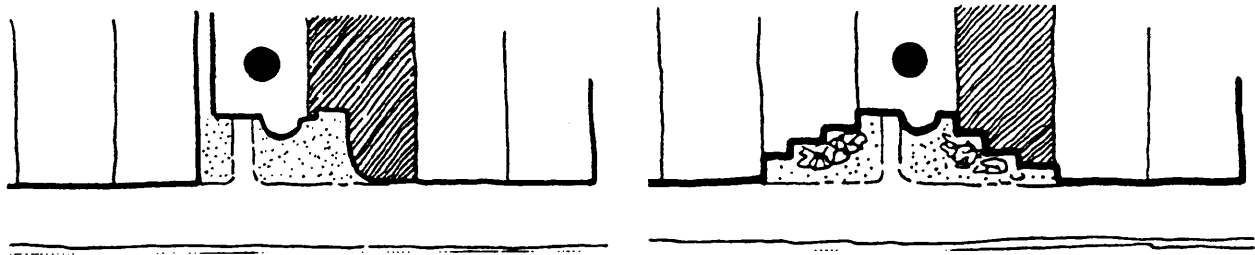

## Provide a Setback to Accommodate Projections of Architectural or Decorative Features

Except for minor encroachments, architectural or decorative features are not permitted to overhang the sidewalk for the first 10 feet above the sidewalk, a height intended to provide the pedestrian adequate headroom. Therefore, in order to allow for appropriate architectural or decorative features at the base of the building, the building may need to be set back from the property line.

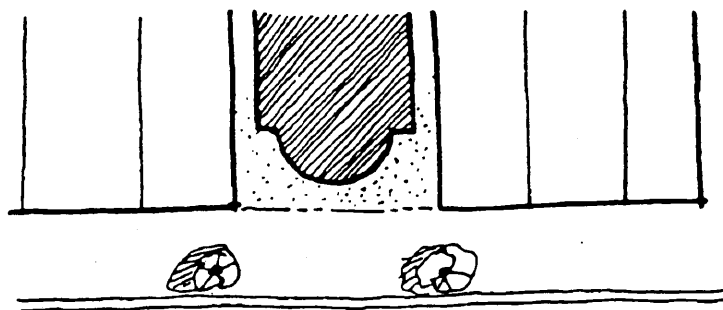

## D. Rear Yards

Rear yards are the spaces between the back of the building and the rear property line. In addition to serving the residences to which they are attached, they are in a sense public in that they contribute to the interior block open space which is shared visually by all residents of the block.

- *Is there a pattern of rear yard depths creating a common open space?*
- *Will changing this pattern have a negative effect?*
- *Are light and air to adjacent properties significantly diminished?*

## Respect Rear Yard and Adjacent Buildings

Intrusions into the rear yard, even though permitted by the Planning Code, may not be appropriate if they fail to respect the mid-block open space and have adverse impacts on adjacent buildings.

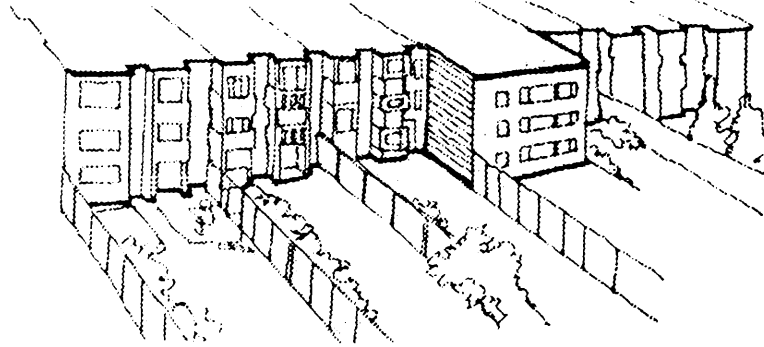

In Cow Hollow, the mid-block open space constituted by the open adjoining rear yards are a major and defining element of the neighborhood character. Preservation of these the mid-block open space is an important goal of these Neighborhood Design Guidelines. Not only should rear additions respect the midblock open space, but they should also minimize adverse impacts on adjacent buildings, such as significant deprivation of light, air and views. Expansions should be designed to avoid overshadowing neighboring gardens, existing sunlit decks, sunny yard space, or blocking significant views.

## Finish the Rear Facade and Visible Sides of the Building

The rear of the building, and the visible sides, while not as public as the front of the building, still are in view of the neighboring properties, and often, depending on the topography, of those far beyond. This facade should also be compatible with the character of its neighborhood. The exposed siding of a rear extension should be architecturally finished because of its visual impact on adjacent properties. Exposed plywood, for example, should be considered inappropriate in the Cow Hollow neighborhood, where the majority of the building facades are finished with siding or stucco.

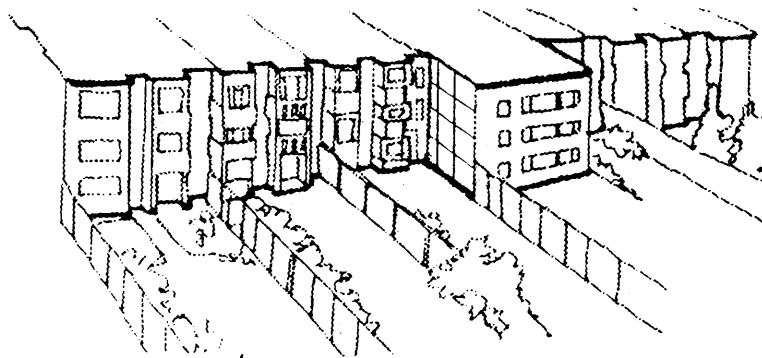

## E. Side Spacing (Side Yards)

Spacings are the separations, existing or perceived, between buildings. Side or “notch-backs” between buildings help to underscore the separate nature of each unit and set up a characteristic rhythm to the street scape composition.

- *Is there a pattern of side spacing between the buildings?*
- *Will changing this pattern have a negative effect?*
- *Can a negative impact be minimized by changing the design?*

### Respect Spacing Pattern

As with front setbacks, a poorly designed side setback between buildings can strongly impact the neighboring buildings as well as be visually disruptive.

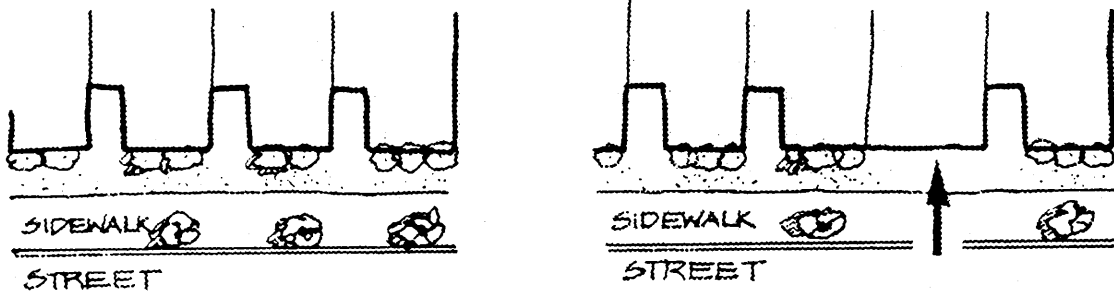

Proposed projects should respect the existing pattern of spacings between buildings.

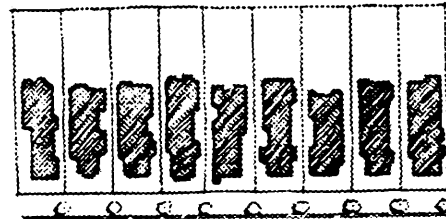

## Incorporate “Good Neighbor” Gestures

Often a small side setback or notch can prevent blockage of a neighbor’s window or light well, or a slight reduction in height can avoid blockage of a view. These kinds of “good neighbor” gestures should be incorporated into the design.

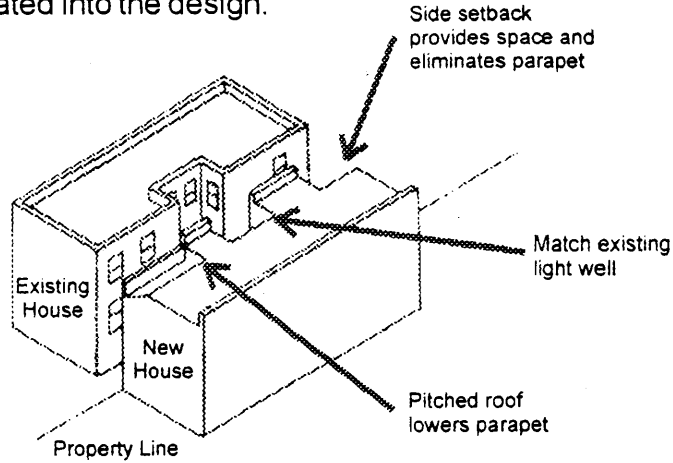

Drawing by Ruth Siegel/Arnold Lerner, AIA

### Ways to Adjust Envelope and Add Light/Preserve Neighbor's Views

## Lateral Lighting, Air and Views

Where side yards exist, new buildings or expansions should be designed so as to preserve these side yards in their entirety and thus to protect the privacy of and light to neighboring buildings. When rear additions impinge on light and air to adjacent homes, setbacks can be used to preserve the extent of light and air intended in the existing design.

## Rear Expansions

In attached homes in Cow Hollow, the lack of side yards limits light received by residences and limits the sight lines (air envelope) around the residences. For this reason, attached homes are particularly vulnerable to deprivation of light and air by a neighboring rear expansion. Therefore, it is particularly important in attached homes that the rear additions be set back at their sides as much as necessary to preserve the existing extent of light and air to adjacent structures, as shown in the following figure.

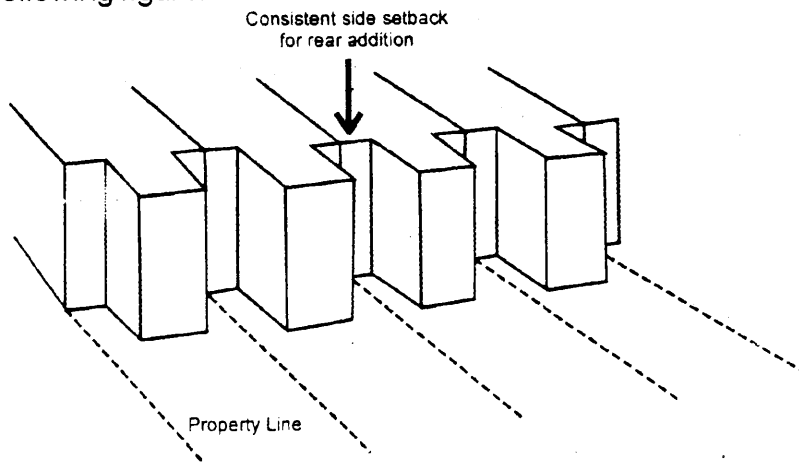

## 2. BUILDING ENVELOPE

The building envelope refers to the exterior elements of a structure – the roof, the front, rear and side facades and other projecting elements such as bays, overhangs and balconies. The actual envelope of a building, within the maximum envelope established by the Planning and Building Codes, should be compatible with the envelopes of surrounding buildings. This section focuses specifically on two aspects of the building envelope which are crucial for compatible design – the **Roofline** and the appearance of **Volume** and **Mass**.

### A. Roofline

The roofline refers to the profile of the building against the sky. In the case of Cow Hollow, where steep slopes expose the design, and appearance of the roof of buildings down hill, roofline also refers to the perception of roofs as seen from higher elevations.

- *Is there an identifiable pattern to the rooflines of buildings on the blockface?*
- *What choices are there to respond to this pattern?*
- *Can the impact of unavoidable disruptions to the pattern be lessened?*

### Respect Roofline Patterns

The style of roofline varies throughout the Cow Hollow Neighborhood from block to block.

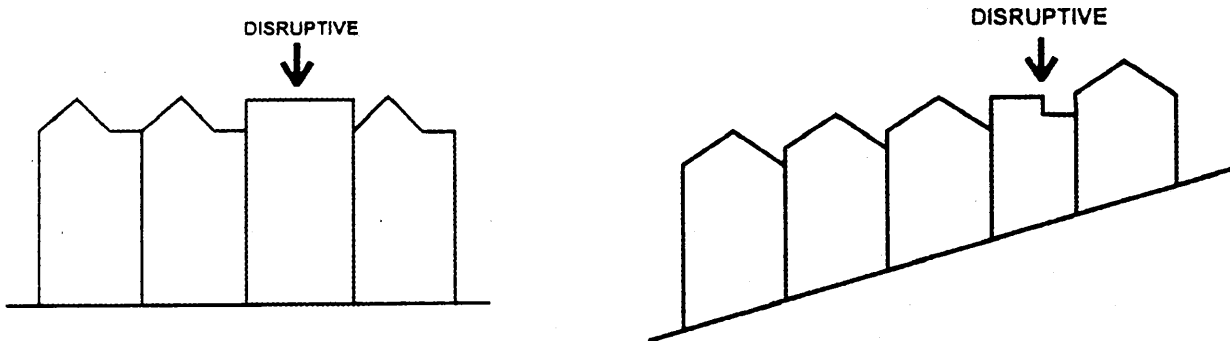

Broad patterns may not be apparent unless the entire block face is considered.

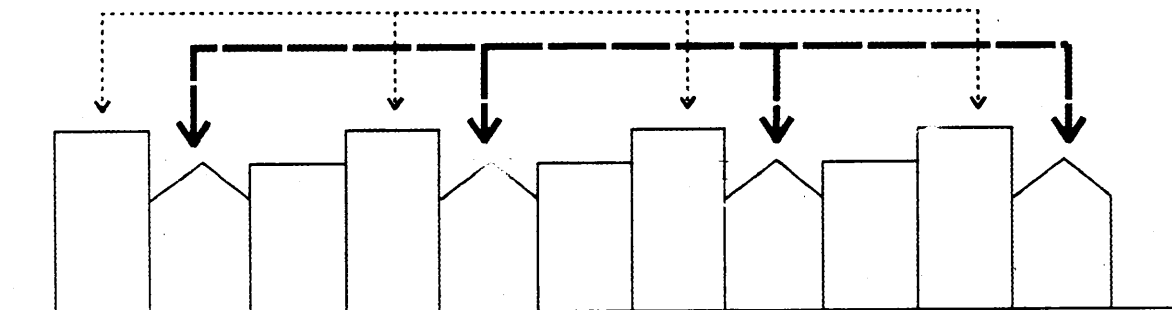

Many blocks throughout the neighborhood are characterized by distinctive roof types, while others are less consistent. Those blocks that are more consistent require design that is consistent and complementary to the dominant building style. Blocks that are more varied and eclectic require special consideration in order to bring greater harmony or visual interest to the blockface.

In general, a strong repetition of consistent rooflines calls for similar design for new construction and alteration.

As important as the pattern of rooflines seen from the street level, is the perception of the roofs of buildings as seen from higher places. A flat roof, the choice of bright and reflective roof materials, the random placement of skylights, the construction of elevator and stair penthouses, or the design of a bulky roof, can greatly affect the neighborhood character as perceived from higher locations within the neighborhood.

### **Minimize the Impact of Inconsistent Building Rooflines**

The impact of inconsistent building forms should be responded to creatively.

There is likely to be more than one way to address a complex pattern of rooflines. While the design may respond more specifically to one pattern over another, picking up on several patterns may help to tie the streetscape composition together.

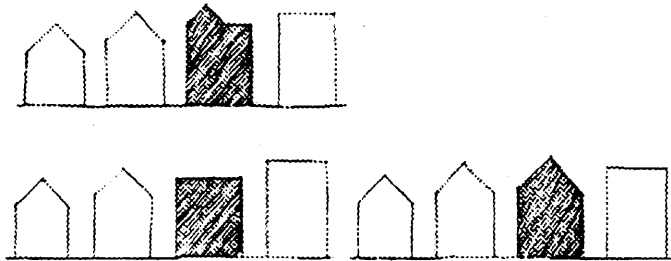

When the inconsistency results from the new building being taller than adjacent buildings, setting the taller element back from the street through a set-back at the prevailing street wall height would be necessary. Corner buildings require setbacks on both frontages.



## **B. Volume and Mass**

Volumes are the three dimensional forms of the building. Mass is created by the combination of arrangement and surface treatment. Mass and volume together define a building's bulk, weight and depth. The appearance of volume and mass influences how people perceive a building as they pass by. San Francisco has a tradition of buildings which exhibit a strong sense of volume and mass; facades tend to have sculptural, three dimensional qualities and the buildings themselves seem to be solidly rooted to the ground.

- ***Have the elements which contribute to the feeling of volume and mass along the block face been identified?***
- ***Can the appearance of compatible volume and mass be created in the new structure with the façade articulation and ornamentation?***

### **Compatibility of Volume and Mass**

The volume and mass of a new building or an addition to an existing building must be compatible with that of surrounding buildings. Corner buildings need to show mass and volume more clearly than mid-block buildings and therefore need special attention.

### **Identify and Incorporate Elements which Contribute to Volume and Mass**

Perhaps the easiest way to understand the forms which influence this design element is to outline them using photographs of the exterior and interior block face and tracing paper. In the following example, both protruding forms and the recessed areas which create the sense of volume and mass have been identified. With this information, the compatibility of the volume and mass of the proposed project can be judged.

Take the original photographs...

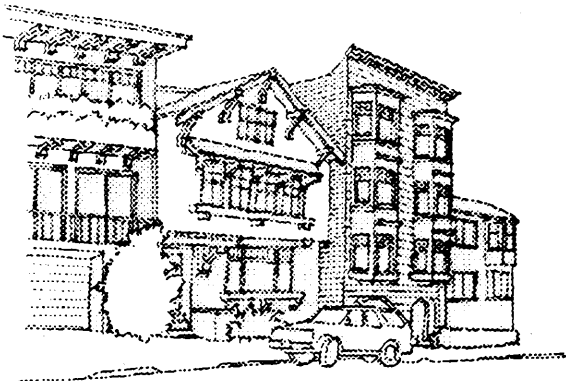

Outline the basic forms...

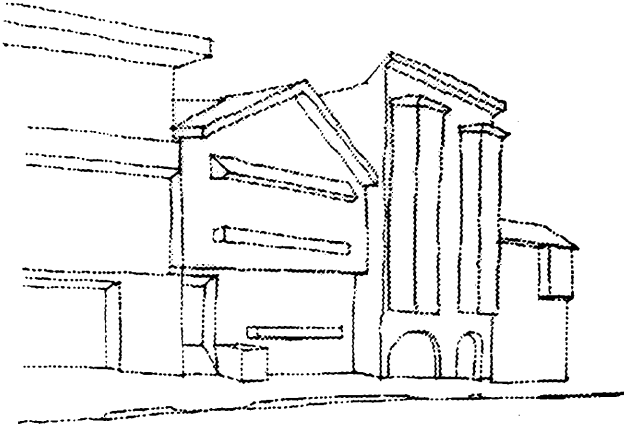

Add shading to identify elements with volume and mass...

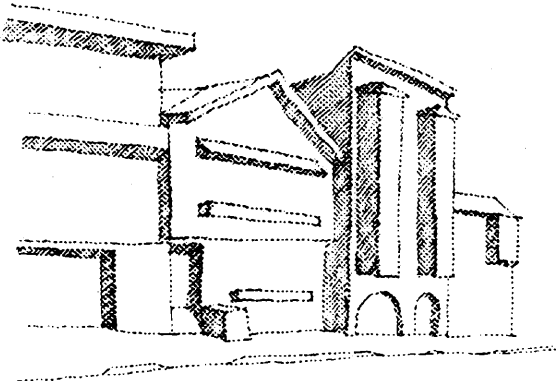

### Effect of Light and Shadows/Ornamentation

Protruding façade ornamentation which casts shadows tends to increase the sense of volume even on a flat façade. The amount and level of detail of the façade ornamentation (see Texture and Details) influence the sense of volume and mass.



Lack of decorative features or use of fine scale decoration tends to create a façade with little sense of volume and mass.



If consistent with the surrounding buildings, the treatment of architectural detail can help to create the appearance of greater volume and mass.

### Effect of Light and Shadows/Openings

Light and shadows cast on a facade help define the sense of volume and mass. Openings in the facade—windows, pedestrian and vehicular entries—play an important role in the creation of shadows. Simple and large shadows accenting recessed areas can provide a greater sense of mass, as in the following example.



### 3. SCALE

The scale of a building is its perceived size relative to the size of its elements and to the size of elements in neighboring buildings. The scale of any new building or building alteration should be compatible with that of neighboring buildings. To assess compatibility, the dimensions and proportions of neighboring buildings should be examined.

#### A. Dimensions

- *Does the building seem under or oversized in relationship to the buildings around it?*
- *Do certain elements of the building seem to be the wrong size in relation to other parts?*
- *Can the dimensions be adjusted to relate better to the surrounding buildings?*

#### Respect the Scale of the Neighborhood

If a building is actually larger than its neighbors, it can be made to look smaller by façade articulations and setbacks. If nothing helps, reduce the actual size of the building.

Buildings may be compatible with their surroundings in terms of proportions, but still be out of scale. Building No. 3 is too high and too wide.

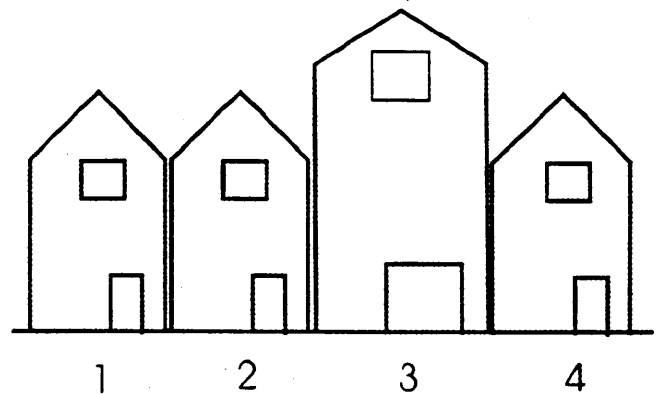

As in the example above, building #3 is bigger than its neighbors but it is in scale with them because the width of the façade has been broken up and the height has been reduced.



## Height

A structure higher than others in its block face or context risks incompatibility. As a result, the height relationship between structures in Cow Hollow has been the source of intensive debate. Several specific height relationships create concern, including:

- down-slope structures with excessively high rear facades blocking light and overwhelming up-slope structures located on the same block
- down-slope structures blocking views from up-slope structures across the street, and
- down-slope structures blocking lateral views and light from up-slope structures when located on a block face perpendicular to the hill slope.
- on moderately or steeply up-sloping lots, to preserve mid-block open space and amenities such as access to overhead light and air, it may be necessary to limit the height of additions to the rear of the house.

In areas of Cow Hollow that are down-slope from the ridge along Pacific Avenue, availability of light to homes is often limited because sunlight is blocked by homes on the ridge, in particular in the winter months. In these areas, vertical expansions that further limit the light are not appropriate. Alternative designs that involve no impact on light should be sought.

## Width

The design of a new building or an addition must be consistent with the existing pattern of building width that prevails in Cow Hollow. Expansion in the side-to-side dimension is possible only in detached homes, provided that the building expansion, does not encroach into a required side yard, or when there is a clear pattern of side yards. Such expansion must minimize the impact on light and air to adjacent homes and preserve side yards by matching existing neighboring side yards.

## Depth

The design of a new building or an addition must be consistent with the existing pattern of building depth that prevails in Cow Hollow. Expansions in depth are generally rear expansions, which are addressed in the section on "Rear Yard."

Extensive rear additions on down-sloping lots, even if they preserve the amenities of neighboring homes, can result in out-of-scale structures that fill up the hillsides and eliminate open space, making the neighborhood appear over built. The many down-sloping lots in Cow Hollow provide ample opportunity to expand within the envelope. However, should a rear extension be desired, to prevent excessive structures on down-sloping lots, it may be necessary to limit the addition so as not to create out-of-scale structures or compromise neighbors' amenities.

## B. Proportions

Proportions are dimensional relationships among the building elements. These relationships exist at several levels: the relationship between the dimensions (height, width and depth) of each element of the building, the relationship of the dimensions of the elements to each other and to the building as a whole, and the dimensional relationship of the building to other buildings along a blockface.

- *Have the prevailing proportions along the blockface been identified?*
- *Can the proportional relationship of the proposed project be identified?*

### Compatibility of Vertical and Horizontal Proportions

The overall sense of a building working well within a particular context is often the result of carefully developed dimensional relationships. Poorly proportioned buildings are out of balance, inconsistent, and lack harmony with their surroundings.

The proportions of the basic shapes of a project must be compatible with those of surrounding buildings. A basic step in identifying the proportions on a block face is to map (as described under 'Volume and Mass') the vertical and horizontal elements that define the facades of a building, such as doorways, windows, cornices and garage doors, and then to analyze their dimensional relationships.

A simple change in proportion can often have an enormous impact on how a building fits into its surroundings. A building with strong horizontal elements in an area where vertical elements predominate can be disruptive. The example below illustrates a change in window proportions. The guideline applies, however, to any element of the facade.

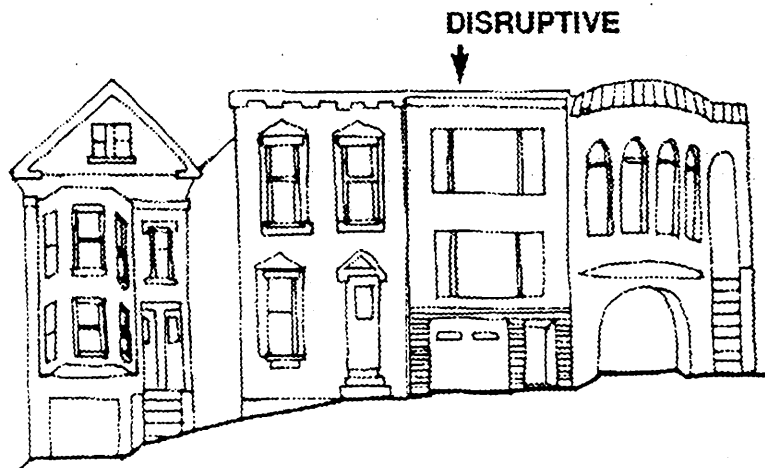

The change in window proportions help make this building more compatible with its context. Other design elements would of course have to be addressed before it would meet the minimum standards of these Guidelines.



## 4. Texture and Detailing

Texture refers to the visual surface characteristics and appearance of the building façade. Detailing refers to the manner in which building parts are put together. The texture and detailing of a building's façade often have the strongest impacts on how people perceive a new structure, and therefore, on their sense of the character of the neighborhood. The use of materials and the degree of ornamentation give the building its texture.

### A. Exterior Materials

Exterior materials are the architectural finish on the visible, exterior parts of the building.

- *Do the building materials complement those used in the surrounding area?*
- *Is the quality of the materials comparable to that of other nearby buildings?*
- *Could the materials be finished in a way that would improve their appearance?*

### Use Compatible Materials

As with other design elements, the surrounding context provides cues for the choice of materials. For example, a metal sided building would not fit in well with a row of painted wood board homes.

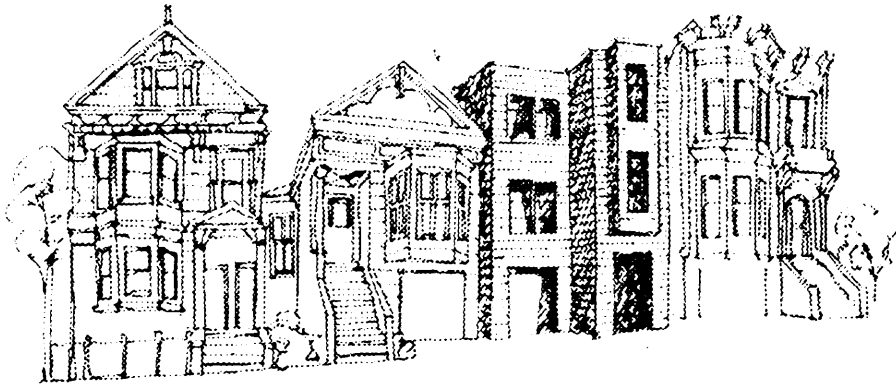

### **Appropriateness of the Choice of Materials**

Attention must be given to how many different materials will be used on a facade, how the materials will be applied and distributed, and what materials are chosen. While in some projects the use of a variety of materials together—stucco, brick, and wood siding, for example—can result in a successful design, in others the variety will seem cluttered and distracting. The key to determining whether choices of material are appropriate is to understand what the design is trying to achieve.

Is the variety of materials being used to create more visual interest in a blank, flat facade? If so, the problem should probably be dealt with by using a more interesting architectural form.

Are different materials being used to define different levels of a building, such as the base, the middle, or the top? The sensitive use of different materials can help express the building's structure in a highly visible manner. In determining what materials are appropriate for this purpose, it is helpful to class the materials by their visual qualities, such as sturdy, massive, heavy, light, delicate, ethereal, etc.

Is the variety of materials responding to a pattern of materials prevalent in the block face? If so, it is helpful to do a careful analysis of what type of materials are being used. Brick, for example, can be clean and smooth, or rustic and knobby, and can change in color and finish. Choosing among the varieties of a specific material is as important as choosing among the materials themselves. Materials should appear as integral parts of the structure rather than 'pasted on.'

The designers of Cow Hollow's early homes used many quality materials, including stucco, tongue-and-groove siding, and brick in front facades, a similar range of materials for other exterior walls, roofs, and wood-frame windows. When refinishing existing exterior walls or

finishing the walls of additions or new construction, or finishing exposed side walls, homeowners should use materials compatible with those in the rest of the block-face. For example, aluminum or vinyl siding should not be used in block faces on which facades are primarily stucco.

In the design of a new building or an addition or renovation, the materials of the existing house as well as the materials of the surrounding buildings need to be considered. The quality of materials and installation should be comparable to those used in the original buildings and appear as an integral part of the structure.

### **Finish Exposed Side Walls**

Exposed sidewalls should be finished with quality materials that are compatible with the front facade and adjacent buildings. Unpainted plywood blends poorly with other materials and should not be used when it is exposed to view.

## **B. Ornamentation**

Ornamentation is the refinement of detail and the application of decorative elements with the sole purpose of enhancing the building's appearance.

- ***Does the project stand out as excessively plain or overly decorated?***
- ***Does the ornamentation make sense for the building or is it simply copied from those surrounding it?***

### **Respect the Amount and Level of Detail of Surrounding Ornamentation**

The richness and level of detail of ornamentation in the surrounding area should be used as a guide, without exactly mimicking the neighboring facades. For example, a relatively flat façade with little ornamentation would be inconsistent in an area which has a high degree of façade ornamentation and vice versa.

In any event, stark, flat facades and large, visible, and undifferentiated side walls should be avoided by articulating their form and/or through the use of ornamentation. All materials and colors should be extended along all exposed sides of the building.

Ornamentation should be used with understanding and restraint, with consideration of the visual character of the neighborhood. The use of decorative brackets, eaves, details, cornices, columns, and capitals, for example, should come from an awareness of the evolution of such building elements and of their original, structural function; columns in old buildings, brackets support overhangs, etc.

Ornamentation has also evolved throughout particular periods of architectural style. An analysis of the predominant era of architecture represented in the neighborhood adjacent to the project will be helpful. A project decorated with Victorian ornament in a neighborhood of stucco buildings typical in the Outer Sunset would seem inappropriate. An understanding of the differences among such important architectural styles in San Francisco as Italianate, Queen Ann, Stick, Colonial Revival, Mission Revival, and Craftsman would be a valuable tool for a designer working in a neighborhood of older, more historic buildings.

Ornament that has been carelessly 'tacked on to' the facade of a building can cause architectural disorder. For example, when the project designer selects window styles and surface materials without clear rationale the building will lack architectural unity and integrity.

Cow Hollow homes vary greatly in ornamentation due to the wide range of architectural styles present in the neighborhood. When building a new structure, if not the ornamentation, at least the effects of light and shadow pertinent to the style of the subject block face must be conveyed. Ornamentation must be used with restraint and in a manner consistent with that of surrounding homes.

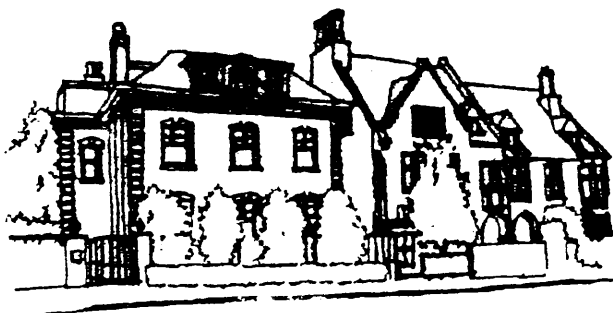
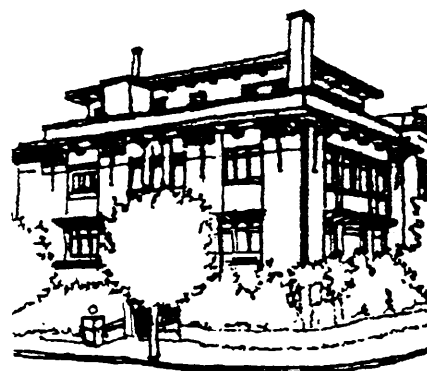

## 5. Openings

Typically, openings in a building—**Doorways, Windows and Garage Doors**—make up the largest and most distinctive elements of a building's façade. While these features have been considered under each of the previous four Design Elements, they are highlighted separately here for clarity of presentation.

### A. Entryways

Entryways refer to the pedestrian, as opposed to vehicular, entries into the building's façade. They comprise doorways, porches, stairs, and other elements that contribute to the sense of arrival into the building.

- *Are the project's doorways compatible in size and details with those around them?*
- *Has a possible existing pattern of stairways been identified?*
- *Does the project respond to this pattern or does it ignore it?*
- *Are the neighboring doorways plain, ornate, prominent or hidden?*

#### Respect Stairway Pattern: Position Level of Entry

Doorways should be designed to be consistent with surrounding entries. In a neighborhood where the predominant pattern of stairways is located on one side of the building, ignoring this pattern could be disruptive. Where symmetry or asymmetry has become an important ingredient of a building group, the goal is to respect it and respond sensitively to it.

Similarly, a ground level entry in a row of structures with raised entries could interrupt an important pattern. It is important to respect a pattern of raised, off center entrances, which may add richness and rhythm to the block face.

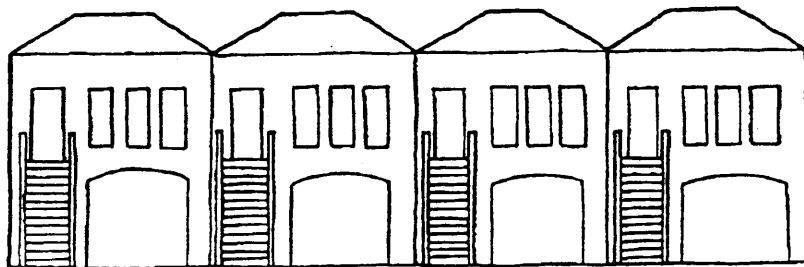

## Respect Entryway Patterns

A building with a small entryway can be disruptive to an area with more elaborate entries. In the example below the doorway appears undersized and inadequate next to the entries with more detailed porticos and decorative features.

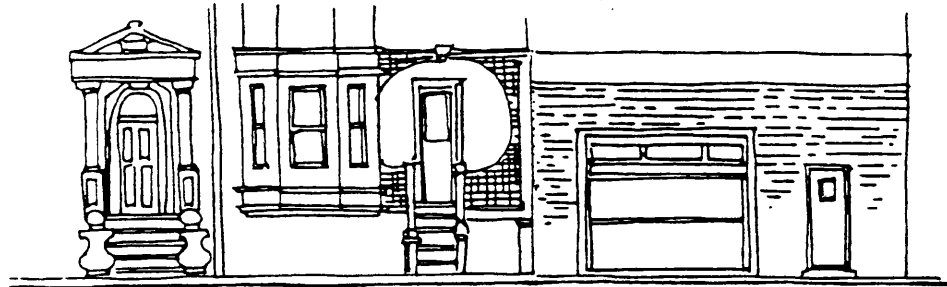

Proposed Entryway

Expanding the scale of the entry by bold framing can help to bring the building into harmony with the surrounding entryways. Cow Hollow entryways generally provide a strong transition from the street to the house and thus exemplify the commitment of the original builders, followed by those of the later periods, to provide maximum privacy to residents of individual houses.

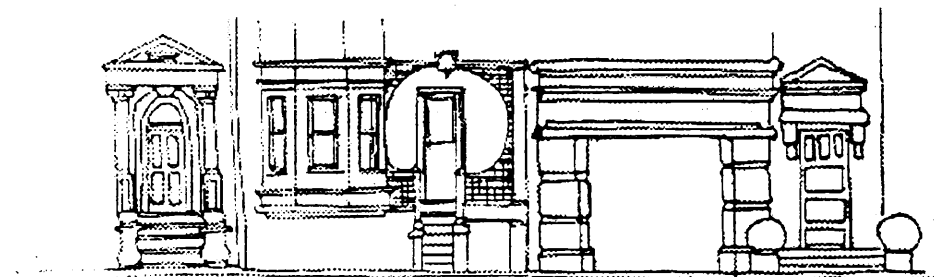

Proposed Entryway

## B. Windows

Windows are the link between the inside, private space and the outside, public space. Windows mark the rhythm along the block face and contribute to the sense of mass of the facades. They emphasize the proportions of a building, can contribute to its ornamentation, and help define its texture.

- ***Is the choice of windows-their configuration, proportions, details and material-appropriate ?***

### **Compatibility of Windows**

The proportion, size and detailing of windows must relate to that of existing adjacent buildings. Most residential buildings have a vertical orientation, while horizontally oriented or even square window shapes are found in commercial and industrial areas. The proportion of window (void) to wall (solid) area on a facade varies with building type. New windows should approximate ratios of neighboring structures while meeting the building's functional needs.

Since windows in most older buildings are framed by a variety of elements such as sash, stained glass, lintels, sills, shutters, pediments, or heads, new structures should avoid designing windows which are not differentiated from the wall plane. Wood window frames are more harmonious with surrounding structures than steel or aluminum frames. Generally, older buildings have inset windows with a generous reveal. Individual windows should be consistent with pane divisions on neighboring buildings, which are often double-hung or casement sash.

### **C. Garage Doors**

Garage doors are the auto entry to the building – the doors, their architectural frame, and the driveway. This element occupies a major portion of the ground floor of a building on the typical narrow lot and therefore has a major impact on the pedestrian perception of the building.

- ***Does the proposed garage door fit in with the rest of the project?***
- ***Is the scale of the garage door compatible with its adjacent garage doors?***
- ***Can the visual dominance of the door be reduced?***
- ***Can its visual appearance be improved?***

### **Compatibility of Garage Entry**

The design of the garage door should be compatible with the scale of the building and other surrounding buildings on the block. It should create visual interest and should be solid so the parked vehicle cannot be viewed from the street.

This garage door presents a dull, blank expanse.

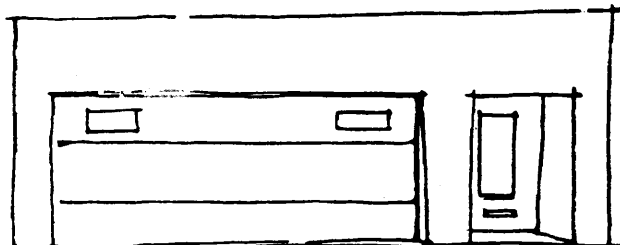

A recessed or arcaded garage door is less intrusive.

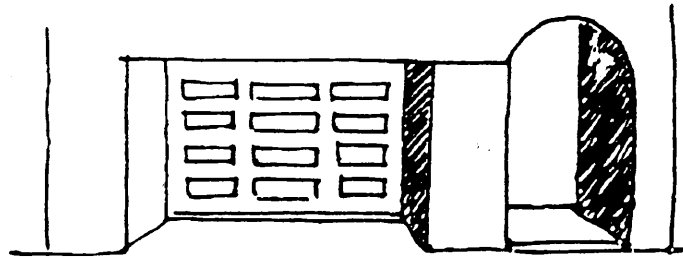

Garage doors can be embellished to make them more attractive.

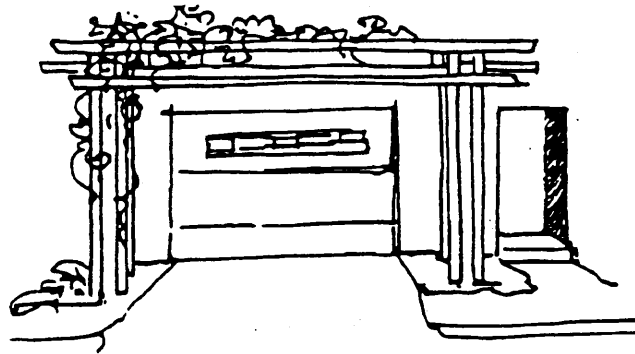

### **Minimize Negative Impacts of Garage Entries**

The garage door is often the largest opening in the front of the building. Care must be taken to prevent it from becoming the dominant feature. In most of the city's residential neighborhoods, the width of the garage doors is between 8 and 12 feet. If the garage is made deep enough, cars can maneuver once inside and the garage door can be reduced and made a less prominent feature of the building façade.

Large lots and multiple lots in a row offer an opportunity to cluster parking areas and minimize the number of garage entries and loss of curbside parking. Because of the shortage of street parking in Cow Hollow, garages are strongly encouraged in renovation and required in new construction. Garages should be incorporated in the main volume of the house and not placed in the front setback area.

## 6. Landscaping

Appropriate landscaping can help improve the character of a neighborhood. Front setbacks provide space for planting shrubs, flowers, and trees.

Even on lots where there is no front setback, opportunities exist for enlivening the facade with containers for plant material. Notches and projections can be designed to incorporate planter boxes on the ground level. At the upper levels, planting areas and planter boxes can be constructed into the railings of decks or balconies.

Sec. 143 of the Planning Code requires planting a minimum of one tree of 15-gallon size for each 20 feet of frontage property along each street and alley. Utilities should be located so that there is adequate room for planting the required street tree. Advance planning for utility hookups should take place to ensure that there is no conflict between the location of the tree well and where the utilities enter the site. The particular tree species and locations are subject to approval by the Department of Public Works Bureau of Streets Use and Mapping. They may be contacted (875 Stevenson Street, Room 460, Phone (415) 554-6700) for a street tree application and pertinent information. Just as the building should be compatible with its neighbors, the landscape materials used should be compatible with the landscape materials used in the surrounding area. If there is a dominant tree species used on the block, usually that species should be the one selected.

Potential impacts to views and sunlight must also be considered when trees and other landscape screening materials, such as tall dense shrubs, are planted in the front and rear setbacks. New planting plans should be reviewed carefully to ensure that neighboring views and sunlight will not be significantly diminished when the landscape elements reach maturity. Existing vegetation should be effectively pruned to open new views or restore old views newly obscured by growing vegetation.

### A. Tree Pruning for the Retention of Mid-Block Open Space

Tree pruning strategies including thinning, skirting up, and crown reduction, can retain access of sunlight and can preserve or restore views. These pruning strategies are graphically depicted in the Appendix.

### B. Tree Selection and Placement for Views

Residents should consult with a registered landscape architect or contractor when designing a new planting plan in order to select and appropriately place vegetation that will accomplish the design goals.

## **SECTION 4**

### **NOTIFICATION, STORY POLES, THE COW HOLLOW ASSOCIATION, AND NEIGHBORHOOD INVOLVEMENT**

#### **NOTIFICATION AND STORY POLES**

Notification to neighbors of an application for residential remodeling or new construction shall be according to the requirements of Section 311 of the Planning Code. Where proposed horizontal or vertical additions to homes will increase the existing envelope of a residence, or when the proposal is a new building, it is recommended that sponsors erect story poles. These story poles shall be installed to indicate the outermost envelope of the building. Poles shall be placed to mark the perimeter corners of the proposed addition or new building, at a height that designates the proposed project's roof. Additional center poles shall be installed to indicate roof peaks, if any. The tops of the story poles can be connected with colored tape or rope in a manner that clearly denotes the envelope and massing of the proposed building. This approach will provide a method for residents who may not be able to interpret design drawings to ascertain the ultimate height and bulk of a building, its potential impact on views, and to make informed decisions regarding a proposed project.

#### **COW HOLLOW ASSOCIATION (CHA)**

The CHA was originally incorporated through the filing of the Club's Articles of incorporation in April 1979. These articles established the CHA as a 501 (c)(3) nonprofit corporation. The bylaws define the purpose of the Association as "educational and charitable." (Bylaws of the Cow Hollow Association, August 25, 1978).

#### **NEIGHBORHOOD INVOLVEMENT**

The process for review of home renovations and new construction subject to the Cow Hollow Neighborhood Design Guidelines should include the following steps.

The sponsor must first review the Cow Hollow Neighborhood Design Guidelines. Before undertaking substantial renovation outside the existing building envelope, or beginning new construction, it is incumbent on the project sponsor to consult the guidelines.

When a preliminary design has been prepared by the project architect or contractor, and there are deviations from the Cow Hollow neighborhood character as defined herein, the project sponsor is encouraged to review the project with the Cow Hollow Association.

In all cases, the project sponsor is encouraged to discuss and review the proposed project with all affected neighbors.

The Association can be reached at: [cowhollowassociation@yahoo.com](mailto:cowhollowassociation@yahoo.com) and the San Francisco Department of City Planning can be reached at 415.558.6377

These steps must be followed:

- 1) Consult affected neighbors as required by the Planning Department (150 foot notice guidelines)
- 2) Contact the Cow Hollow Association President for the date and time of the next meeting of the Association in order to schedule a presentation
- 3) Make a presentation to the Cow Hollow Association Board at the regular meeting
- 4) Make necessary adjustments to the design during the conceptual design phase, before working out specific design details, in order to avoid duplication of work and difficulty making adjustments.

The Cow Hollow Board of Directors serves to uphold and enforce the Cow Hollow Design Guidelines as stated and will do its best to provide guidance and suggestions for all inter

# APPENDIX



### A. Zoning Districts of Cow Hollow Neighborhoods

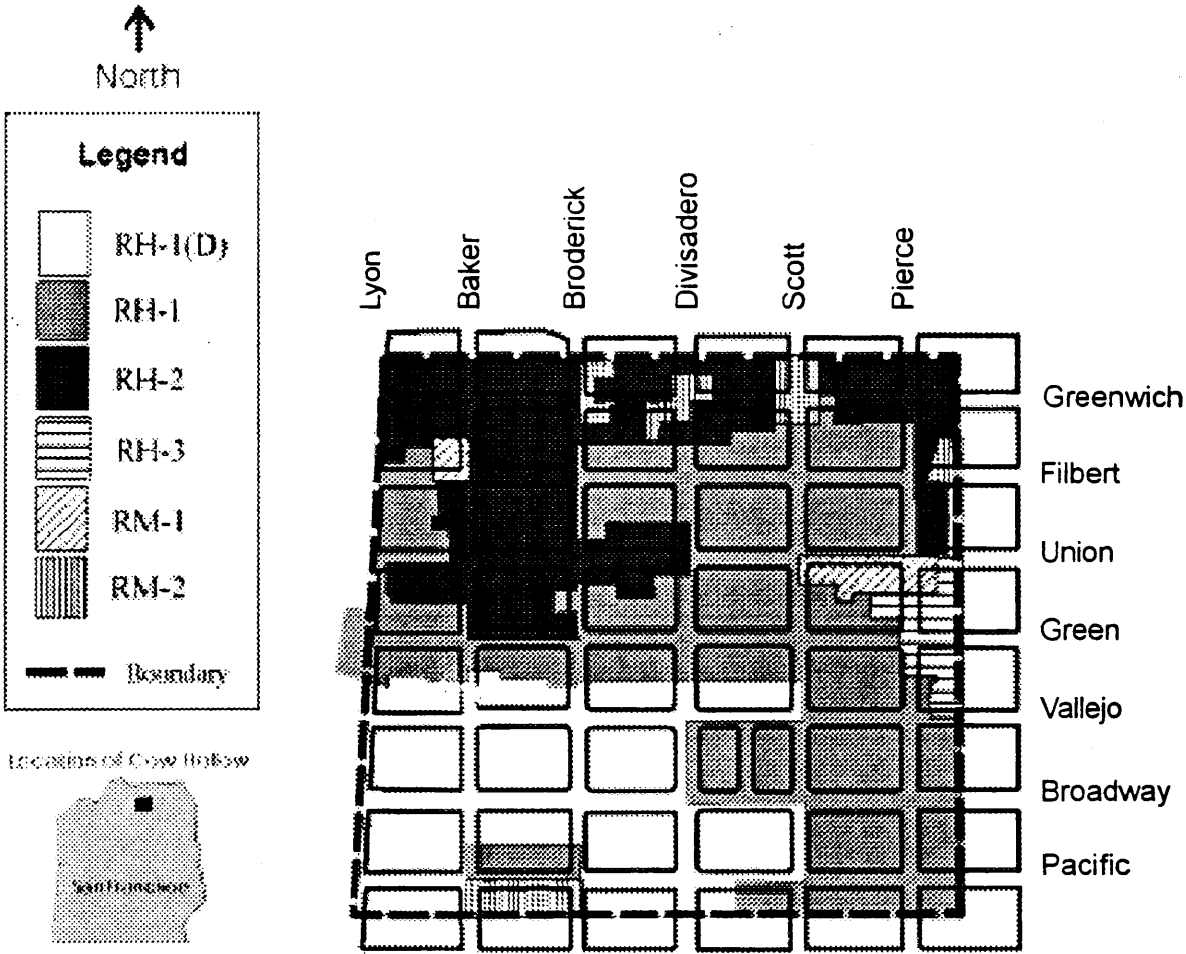

Source: San Francisco City Zoning Map

## **B. Analysis of Rear Yard Coverage and Importance to Neighborhood Character**

Although Cow Hollow is visually eclectic from the block face perspective, the majority of lots share lot and building dimensions that are important to neighborhood character. Analysis of key lot and building dimensions by the Cow Hollow Association, demonstrates that these dimensional characteristics are central to preserving neighborhood character.

The Cow Hollow Association analyzed building height and lot coverage statistics compiled from the Sanborn insurance maps for each of the 1,100 neighborhood lots.

Cow Hollow is an urban neighborhood that is predominately built out, with open space confined to the rear yards and block interiors. Yet, as discussed in this document, existing zoning allows for expansion of existing buildings into the rear yard. The principle threat to rear yard open space is the 75 percent lot coverage allowed under the RH-1 zoning district, leaving only 25 percent rear yard open space. The RH-2 zoning district sets a limit of 55 percent lot coverage, preserving 45 percent of the lot as rear yard open space -- a standard that better protects the rear yard amenities valued by residents of the Cow Hollow Neighborhood.

As shown by the table on the adjacent page, 83 percent of the RH-1 and RH-1(D) lots could expand into the rear yard space under the existing Planning Code 25 percent rear yard requirement. This is 43 percent of the 1100 lots in the neighborhood, as shown in the table. Full buildout of these lots would severely diminish the valuable rear yard open space and access to light, air and views for many neighbors. A large percentage of the rear yard open space that is currently shared by residents throughout the Cow Hollow Neighborhood would disappear in this scenario. Under a 45 percent rear open space requirement, 46 percent of the RH-1 and RH-1(D) units could still expand, while preserving valuable shared neighborhood assets.

Under the existing 45 percent rear yard open space requirement for RH-2 lots, 30 percent of the RH-2 properties in the neighborhood can expand further into the rear yard. As a comparison, this is fewer allowable expansions than would be allowed for RH-1 lot owners under a neighborhood-wide 45 percent rear yard open space requirement.

The chart on the following page illustrates the distribution of RH-1, RH-1(D) and RH-2 lots according to the percentage of rear open space. The chart shows the number of lots for each 5 percent block of rear yard open space, ranging from 0 to 5 percent rear open space (95 to 100 percent buildout) to 95 to 100 open space (partially built or vacant lots).

Roughly one third of the blocks (10 blocks) in the Cow Hollow Neighborhood have a mix of RH-1 and RH-2 zoning (shown in Cow Hollow Zoning Map in Section 1 of this document). This mix of zoning has the potential to generate conflict as neighbors seek to maximize different property values on adjacent RH-1 and RH-2 lots, such as increasing the building envelope versus preserving access to rear yard open space. Because the rear yard open space is a value shared by all lots on a given block, it is important to protect this important aspect of neighborhood character.

The Cow Hollow Neighborhood Design Guidelines do not address rear yard coverage for the other zoning districts in the Cow Hollow Neighborhood, including: RH-1(D), RM-1, RM-2 and RM-3.

**RH-1 Rear Yard Expansion: Effect on Neighborhood Character**

<b>How Many RH-1 &amp; RH-1(D) Lots Can Expand Under Different Lot Coverage Policies?</b>			
	<i>Number</i>	<i>% of Total RH-1</i>	<i>% of Total Neighborhood</i>
25% Rear Yard Open Space requirement?	<b>482</b>	<b>83%</b>	<b>43%</b>
45% Rear Yard Open Space requirement?	<b>268</b>	<b>46%</b>	<b>24%</b>
<b>How Many RH-2 Lots Can Expand Under Existing Policy?</b>			
	<i>Number</i>	<i>% of Total RH-2</i>	<i>% of Total Neighborhood</i>
45% Rear Yard Open Space requirement?	<b>119</b>	<b>30%</b>	<b>10%</b>

**C. Analysis of Building Height and Importance to Neighborhood Character**

Building height, including front and rear façade heights, is another key element of Cow Hollow neighborhood character. The neighborhood is dominated by three story structures, providing a uniform sense of scale along the majority of block faces and preserving a sense of open space in the majority of rear yards. Existing zoning, however, has not preserved these valued characteristics in all situations. The San Francisco Planning Code does not address complex situations such steeply sloping lots in a manner that consistently preserves access to light, air and views for neighbors of properties expanded to the maximum allowable building envelope.

RH-1, RH-1(D) and RH-2: Rear Yard Open Space

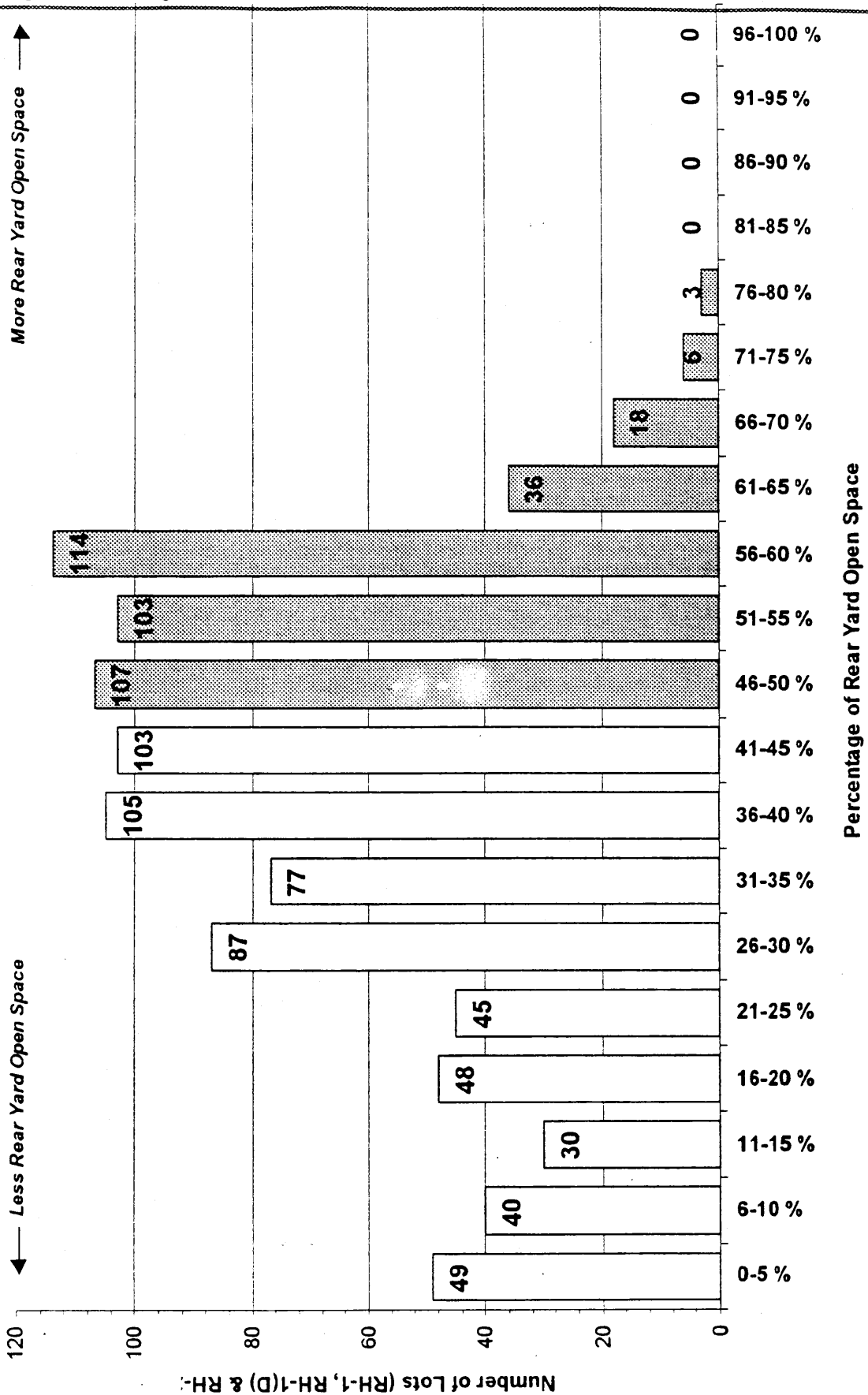

Analysis of Cow Hollow building heights reveals that 98 percent of the structures are from two stories to three and one half stories. 56 percent of the homes are three stories. The few taller structures, 4 stories and taller, are confined to less than two percent of the total number of neighborhood buildings. Among the 4 story structures, roughly one third occur in the RM multi-family zoning districts located primarily at the northern edge of the Cow Hollow Neighborhood. The other taller structures, 5 and 7 stories, are anomalies in the neighborhood, such as the few larger apartment buildings and foreign government consulates.

The chart below illustrates the distribution of neighborhood building among the various height categories, clearly showing the concentration of three-story structures.

These neighborhood design guidelines, in response to the analysis presented in this section, focus not only on the visual elements of design but establish specific guideline policies addressing the dimensions for new construction and renovation, including: building height, rear yard setback, lot coverage, and side yard dimensions. These individual topics are discussed in more detail in Section 3.

**Cow Hollow Building Heights**

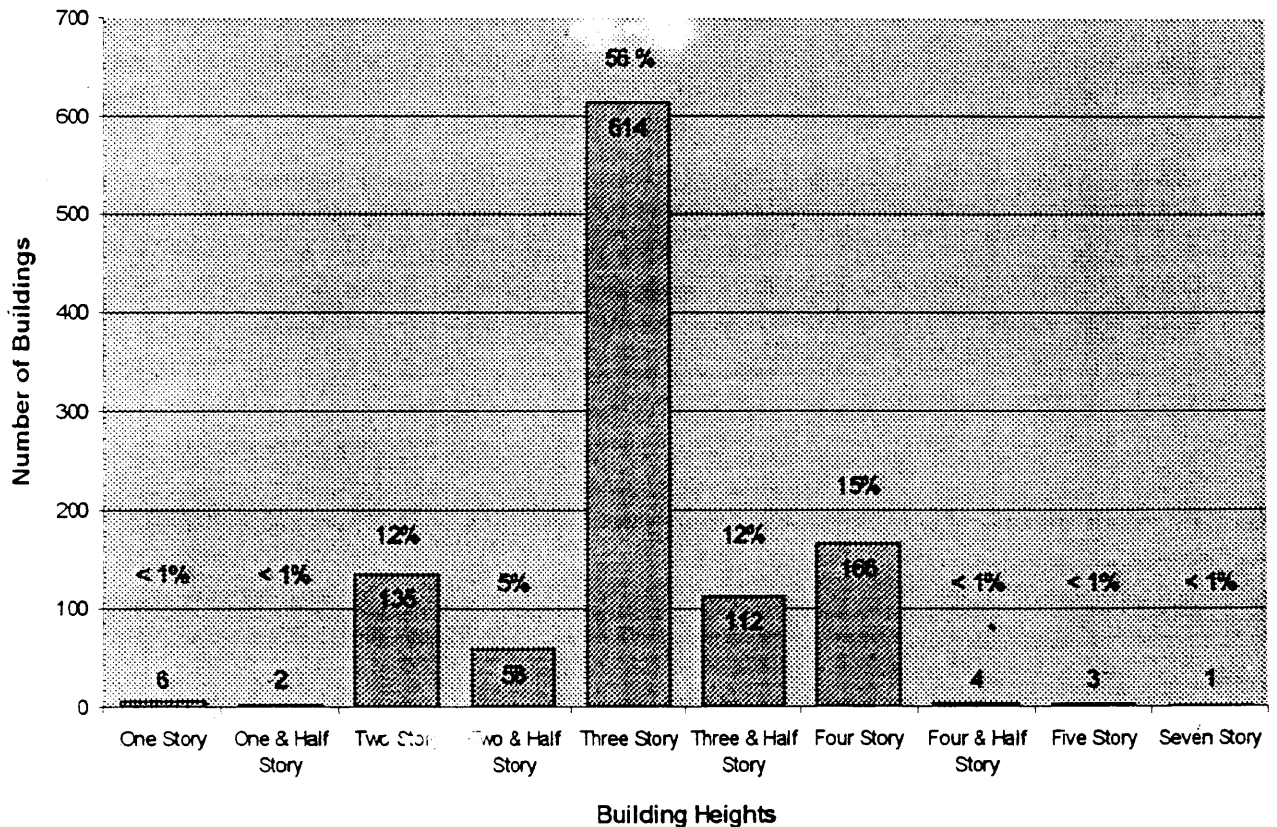

## D. Cow Hollow Association Policies

### D.1 Rear Yard Setbacks and Open Space

As described above in the section Cow Hollow Neighborhood Character, the Cow Hollow Neighborhood is zoned predominately RH-1 and RH-2. The San Francisco Planning Code establishes a 25 percent rear yard open space requirement for the RH-1 zone, meaning the building may cover 75 percent of the lot. The Planning Code requirement for the RH-2 zone is a 45 percent open space requirement, or, the building may cover 55 percent of the lot. Because the RH-1 and RH-2 zones are intermingled, as shown in zoning diagram figure in Section 1, the Cow Hollow Neighborhood would benefit from a consistent rear yard open space requirement.

**Cow Hollow Neighborhood Policy:**

**New construction and additions outside of the existing building envelope in both RH-1 and RH-2 zones must follow an overriding 45 percent rear yard open space policy. (See Next Page for Diagram)**

This policy will primarily limit expansions of existing homes within the RH-1 zone. According to analysis performed by the Cow Hollow Association, presented in greater detail in the Cow Hollow Neighborhood Character section of this document, 34 percent of the RH-1 lots can expand under this policy (169 lots). The remainder of the lots (328 lots) are built out, with 55% or greater lot coverage. This rear yard policy, however, must be considered along with the rear yard equalization policy, described immediately below.

**Cow Hollow Neighborhood Policy: The only time an extension into the 45 percent rear yard open space requirement is allowed is when both adjacent neighbors intrude into that space. The extension must be measured by "equalization" to the more complying of the two adjacent properties. (See Next Page for Diagram)**

### Cow Hollow Neighborhood Policy RH-1 and RH-2 Rear Yard Setback

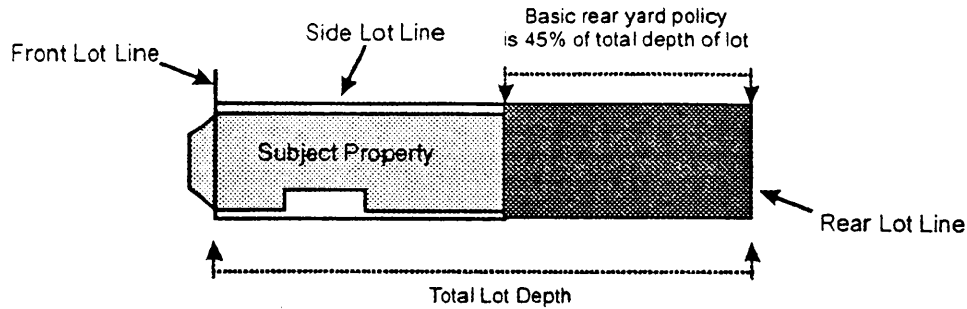

### Cow Hollow Neighborhood Setback Policy compared to Planning Code:

**RH-1: Reduction in building footprint from 75 percent lot coverage to 55 percent lot coverage.**

**RH-2: No reduction in building footprint.**

### Cow Hollow Neighborhood Policy Rear Yard Equalization for RH-1 and RH-2

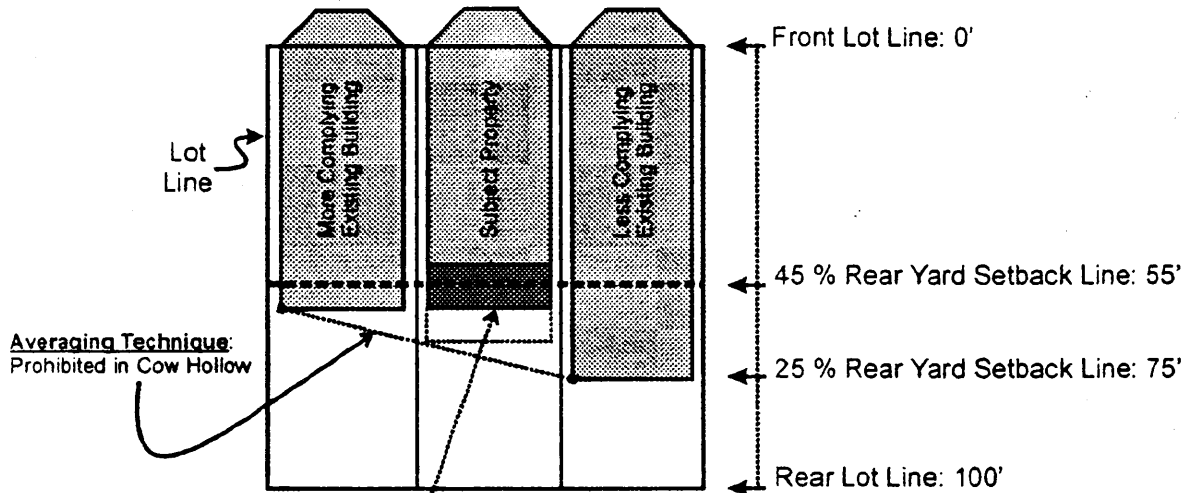

**Equalization Technique:** Intrusion into the 45 percent rear yard space should be allowed only when both neighbors are within the 45 percent area. In this case, the subject property may expand to the more complying of the two adjacent properties. Equalization is distinct from “averaging,” as depicted.

Equalization should be based on legally installed and permitted extensions. If a neighbor has an illegally constructed rear yard extension, equalization based on measurement of the illegal structure should not be allowed. Equalization is distinct from averaging, which allows for creeping into the rear yard space indefinitely.

## D.2 Rear Yard Extensions

Rear yard extensions allowed by the Planning Code often have overwhelming impacts on rear yards. The 12 foot extension allowed by the code is prohibited in the Cow Hollow neighborhood, in order to preserve the limited rear yard open space in the neighborhood. Generally, these extensions diminish midblock open space by breaking the continuity of views and green space shared by neighboring rear yards.

**Cow Hollow Neighborhood Policy: No 12-foot rear yard extension. The 12-foot extensions allowed by the Planning Code is prohibited in the Cow Hollow Neighborhood in order to preserve valuable midblock open space.**

### Finish of the Rear Façade and Visible Sides of the Building

The rear of the building, and the visible sides, while not as public as the front of the building, still are in view of neighboring properties and often, depending on topography, of those far beyond. This façade should also be compatible with the character of its neighborhood. The exposed siding of a rear extension should be architecturally finished because of its visual impact on adjacent properties.

Exposed plywood, for example, is prohibited in the Cow Hollow Neighborhood where the majority of building facades are finished with shingle, brick, siding or stucco.

D.3 Height

These Neighborhood Design Guidelines generally include lower building heights as compared with what is permitted under existing zoning requirements.

**Cow Hollow Neighborhood Policy:** The overriding policy established in these Cow Hollow Neighborhood Design Guidelines is a 35 foot height for RH-1(D), RH-1 and RH-2.

Height policies include lower heights for some lot configurations, where appropriate to help preserve neighborhood views, and access to light and air. Diagrams are included for clarification of the neighborhood height policy for level lots, steep up-sloping lots, and steep down-sloping lots in RH-1(D), RH-1 and RH-2 zoning districts.

The figures included in the following pages diagram level, steep down-sloping, and steep up-sloping height requirements for RH-1(D), RH-1 and RH-2 zoning districts.

Height policies stated in the Cow Hollow Neighborhood Design Guidelines are intended to be absolute, meaning that no roof appurtenances such as parapets, elevator and stairway pent-houses are permitted.

**Neighborhood Height Policy Table**

District	Slope/Elevation Difference	Height Policies	
		Front Height	Rear Height
RH-1(D), RH-1, and RH-2 districts with a mapped height of 40 feet or less	Level Lots: gently up-sloping & down-sloping: less than 10' elevation difference	35 ft.	35 ft.
	Steep Down-Sloping Lots: average ground elevation at rear yard setback line is lower by 10 ft. or more than elevation at front lot line	30 ft.	30 ft.
	Steep Up-Sloping Lots: average ground elevation at rear yard setback line is higher by 10 ft. or more than elevation at front lot line	30 ft.	25 ft.

Note: See diagrams for complete neighborhood height policies for level, up-sloping and down-sloping lots.

**Level Lots:** less than 10 feet change in elevation from front lot line (or front setback) to rear yard setback line

**Overriding 35 ft. Maximum Height for level lots  
RH-1(D), RH-1 and RH-2 districts**

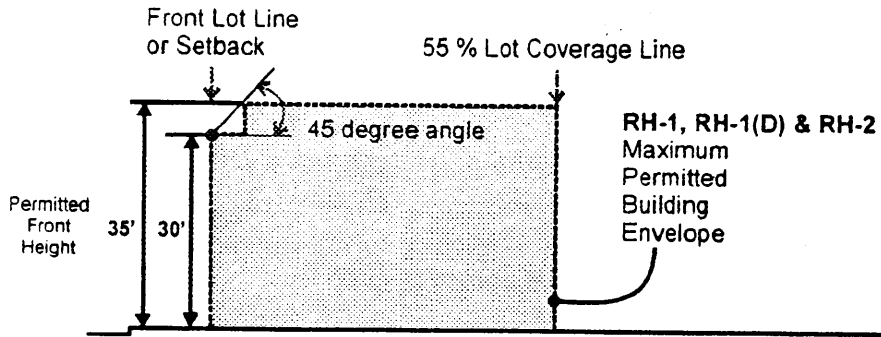

**Steep Down-Sloping Lots**

10 foot or greater drop in elevation from front lot line (or front setback) to rear yard setback line

**Overriding 30 ft. Maximum Height**  
 30 ft. Maximum in RH-1(D) and RH-1 districts  
 30 ft. Maximum height in RH-2 districts

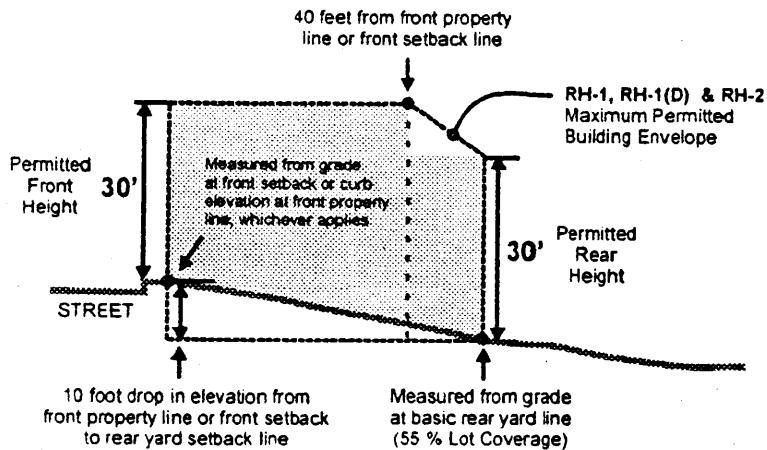

In addition, the permitted front height for RH-1 is reduced to 25 feet, by the Planning Code, where the average ground elevation at the rear lot line is lower by 20 feet or more than at the front line thereof.

**Steep Up-Sloping Lots**

10 foot or greater gain in elevation from front lot line (or front setback) to rear yard setback line

**Overriding 30 ft. Maximum Height**

30 ft. Maximum in RH-1(D) and RH-1 districts

25ft. Maximum height in RH-2 districts

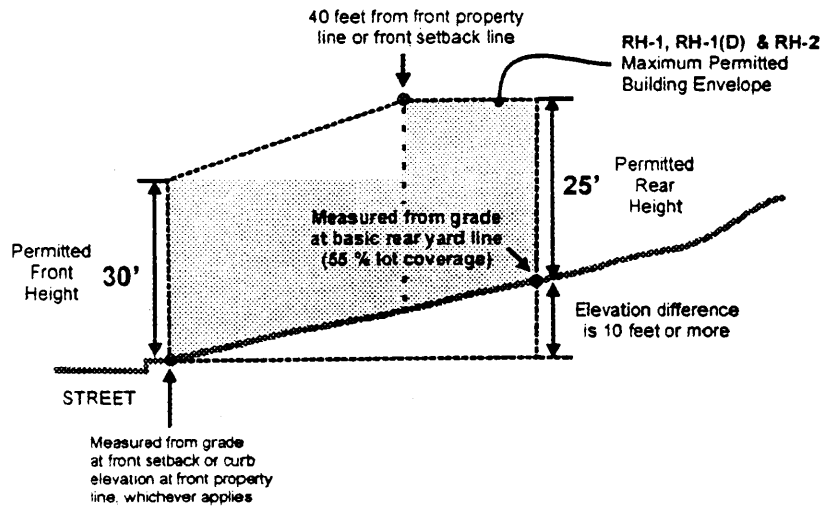

#### D.4 Tree pruning techniques for View Preservation

Topping—reducing the height of a mature tree by sawing back its top limbs—is not a solution. This pruning technique produces weak secondary growth which often increases the height of the tree while diminishing its health and appearance. A professional arborist should be consulted in large scale pruning projects.

The illustration on the following page depicts appropriate pruning techniques that can enhance and preserve neighborhood views.

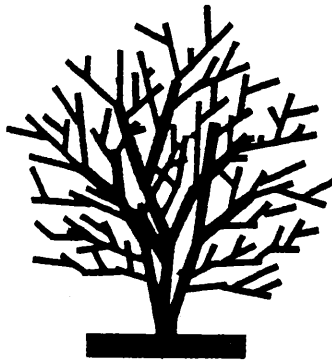

Dense mature trees can block views from multiple elevations. Consult with a professional arborist regarding the pruning techniques illustrated below to restore obscured views.

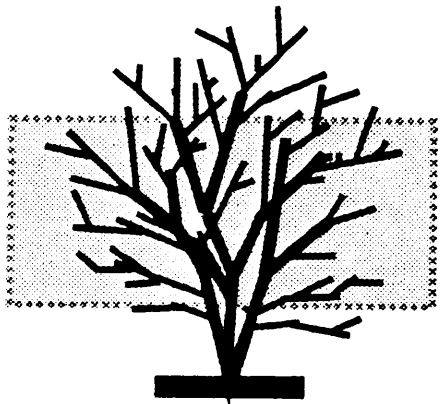

**Thinning:**  
Removing some of the lower limbs can reveal a view without ruining the lines of the tree.

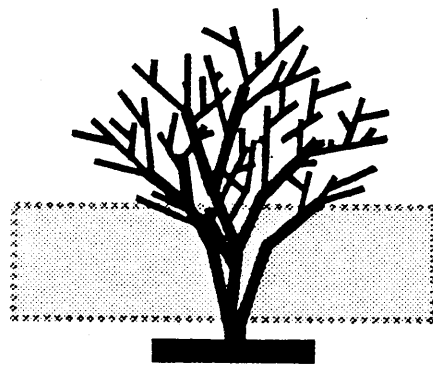

**Skirting Up:**  
Removing some of the lower limbs can reveal a view without ruining the lines of the tree.

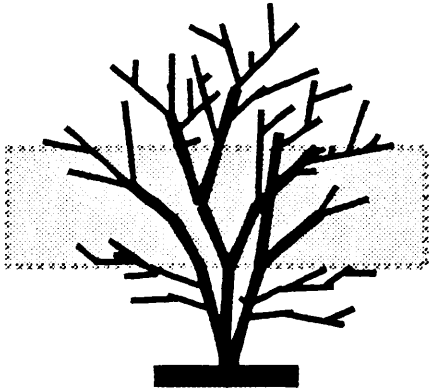

**Windowing:**  
By selectively removing lateral branches, the tree is opened, creating a framed view or views of whatever lies beyond.

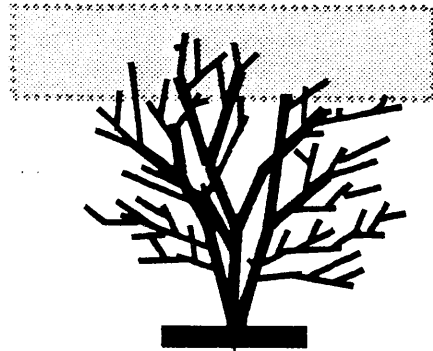

**Crown Reduction:**  
To lower the tree's canopy, use the technique called crown reduction, which reduces the size of the tree while retaining natural growth lines (IMPORTANT: DO NOT TOP-- SEE TEXT)

E. Shadow Study

## F. Height Ordinances

### **Hiller Highlands View Protection**

In writing Design Guidelines for the rebuilding of the Hiller Highlands homes in the Oakland Hills after they were destroyed by fire, architects pointed out that “the most remarkable feature of the Hiller Highlands site is the view”, and that the views “should be preserved”. (Elbasani and Logan, 1992, p.4). The architects determined that plans for the original homes had been designed to preserve “unobstructed views above a +4 degree angle of declination. On houses or garages where the ridge line would have projected above the 4 degree view line of its uphill neighbor, a flat roof was substituted for the typical 4/12 pitch gable roof”. In the rebuilding of the Hiller Highland Homes, the Design Guidelines include similar restrictions, except when uphill neighbors agree to allow some view obstruction for the sake of the more picturesque gable roof.

### **Town of Tiburon View Protection**

One goal of the Town of Tiburon Design Guidelines for Hillside Dwellings [Synopsis] 91981, James S. Malott, for the Tiburon Planning Department) is “to preserve existing views as much as possible and allow new dwellings access to views similar to those enjoyed from existing dwellings” (G3 p.1). Principles of the Guidelines intended to help preserve views include:

- “Locate all new dwellings so they interfere minimally with views of adjacent dwellings.
- Certain parts of the view, important features, the horizon line, center of view, slot views, are more important than other areas of views. Avoid blocking these sensitive areas.
- Measuring a view for blockage, be sure to present the entire view from view stop on left to view stop on right, in order to present the problem completely.
- Other important presentation techniques include story poles with ridge strings, photos including story poles, photos from neighboring vantage points, models, perspectives, surveys, landscaping plans, plans/sections and elevations.”

While Hiller Highlands and Tiburon Hillside Design Guidelines provisions apply to lots larger than those in Miraloma Park, and therefore offer some options for the placement of structures that may not be available to Miraloma Park homeowners, many of the guidelines and techniques presented in these documents can be helpful to designers of projects in Miraloma Park in preserving the views that the original developers of the neighborhood planned for its homes.

Other principles in the Tiburon Residential Design Guidelines relate primarily to reducing the bulk of a structure; however, these principles may pertain to reducing impact on views in some

circumstances, and include:

- “Cut building into hillside, terrace the building up the hill, use underground spaces for functions to reduce visual bulk.
- Break up mass of structure into individual elements, use small scale forms, varying materials and features to break up large scale masses.
- Make building from follow hillside slope and contours so building will flow with landscape.”

### **City of Berkeley View Protection**

The City of Berkeley’s Zoning Ordinance establishes a separate designation for hillside areas (“H District”) in order to protect the neighborhood character and views in areas similar to Miraloma Park.

The purposes of the H. District shall be to protect the character of Berkeley’s hill districts and their environs; to give reasonable protection to views yet allow appropriate development of all property; and to allow modifications in standard yard and height requirements when justified because of steep topography, irregular lot pattern, unusual street conditions, or other special aspects of hillside areas (Berkeley Zoning Ordinance, Section 14.01 - Regulations for H Districts, Purposes).

Although to some extent the assessment of the impact of an addition to an existing structure on views from surrounding homes is subjective, the above Bay Area residential design guidelines and zoning ordinances show that it is possible to apply guidelines that help to make these subjective assessments fair to both holders of existing views and those wishing to build. It is also possible to formulate some objective criteria to minimize the obstruction of existing views. These communities endorse a combination of such objective measures and professional judgements by planning staff in evaluating the effects of vertical additions on views.

### **References**

1. Hiller highlands title page and page 4
2. Tiburon Guidelines: additional information

Note: Text of references available from Miraloma Park Improvement Club.



Book 10000 : 901-6700  
A. B. C. D. E. F. G. H. I. J. K. L. M. N. O. P. Q. R. S. T. U. V. W. X. Y. Z.

---

## ■ Landscaping

Appropriate landscaping can help improve the character of a neighborhood. Front setbacks provide space for the planting of shrubs, flowers and trees.

Even on lots where there is no front setback, opportunities exist for enlivening the facade with containers for plant material. Notches and projections can be designed to incorporate planter boxes on the ground level. At the upper levels, planting areas and planter boxes can be constructed into the railings of decks or balconies.

Sec. 143 of the Planning Code requires planting a minimum of one tree of 15-gallon size for each 20 feet of frontage of the property along each street and alley. Utilities should be located so that there is adequate room for planting the required street tree. Advance planning for utility hookups should take place to ensure that there is no conflict between the location of the tree well and where the utilities enter the site. The particular tree species and locations are subject to approval by the Department of Public Works Division of Urban Forestry. They may be contacted at 695-2162 for a recommended street tree list, *The Urban Forest Information Booklet*, and for a street tree application.

Just as the building should be compatible with its neighbors, the landscape materials used should be compatible with the landscape materials used in the surrounding area. If there is a dominant tree species used on the block, usually that species should be the one selected.



SAN FRANCISCO  
PLANNING COMMISSION  
RESOLUTION NO. 16147

**ENDORISING THE COW HOLLOW NEIGHBORHOOD DESIGN GUIDELINES**

WHEREAS the Residence Element of the City's General Plan establishes policies for preserving existing housing and neighborhood character while encouraging new "in-fill" housing construction; and

WHEREAS, Cow Hollow is one of San Francisco's urbane residential neighborhoods, built incrementally over the past one hundred years with a rich mix of architectural styles and building types. The area is characterized by sweeping views of San Francisco Bay, tree lined streets, gracious and comfortable residences and some apartment buildings located mainly on the northern portion of the neighborhood; and

WHEREAS, Topographically, Cow Hollow slopes down and northward from Pacific Heights, the Cow Hollow neighborhood being defined and organized by the City's traditional grid street pattern, with streets running both parallel and perpendicular to the land slope. The land slope of the Cow Hollow, combined with the proximity of this neighborhood to the Presidio National Park, and to San Francisco Bay, provides a background for public views, characterized by rows of homes, separated by bands of vegetation, that ascend towards a ridge that runs East West, and that forms what constitutes San Francisco's northern facade; and

WHEREAS, As the City's housing stock ages, it becomes increasingly important to maintain it, to bring it to current safety and sanitary standards and to adapt it to the needs of their occupants, while conserving and protecting neighborhood character in order to preserve the cultural and economic diversity of our neighborhoods; and

WHEREAS, As a means to accommodate the needs for enlargement, replacement and new housing construction, while conserving and protecting neighborhood character, the Planning Commission enacted in January of 1996 Section 311 of the Planning Code, the Residential Review Procedures, which require that construction of new residential buildings and alteration of existing residential buildings in residential districts, to be consistent with the design policies and guidelines of the General Plan and with the "Residential Design Guidelines" as adopted and periodically amended for specific areas or conditions by the Planning Commission; and

WHEREAS, the Cow Hollow Association, with the guidance of the Planning Department undertook the elaboration of specific guidelines that address the topographic and climatic constraints and the character of buildings of their neighborhood; and,

WHEREAS, On March 22, 2001, after an informational presentation of the Neighborhood Design Guidelines to the Planning Commission, the Cow Hollow Association was instructed to work with Planning Department staff to finalize the propose guidelines; and

WHEREAS, The Cow Hollow Association has successfully concluded the refinement of the

Neighborhood Design Guidelines and completed the graphic materials that adequately support the "Cow Hollow Neighborhood Design Guidelines".

THEREFORE BE IT RESOLVED, that the Planning Commission hereby endorses the "Cow Hollow Neighborhood Design Guidelines" which advance policies contained in the Residence, and Urban Design Elements of the General Plan and which require no changes to existing city codes; and

BE IT FURTHER RESOLVED, that the Planning Commission and Planning Department staff will consider the Cow Hollow Neighborhood Design Guidelines" in their evaluation of development proposals within Cow Hollow, pursuant to Section 311 of the Planning Code and relevant policies of the City's General Plan, and will encourage their use by project sponsors and their designers in the project design process, and by neighbors and community groups in their review of projects; and

BE IT FURTHER RESOLVED, That the "Cow Hollow Neighborhood Design Guidelines" will be made available for purchase at the Planning Department for prospective purchasers and/or developers of property, residents and owners within Cow Hollow, and the general public.

I hereby certify that the foregoing Resolution was adopted by the Planning Commission on April 26, 2001

Linda Avery  
Secretary

AYES: Theoharis, Baltimore, Chinchilla, Fay, Joe, Salinas  
NOES: None  
ABSENT: None  
ADOPTED: April 26, 2001

cowhlres